

 **apple computer**  
20525 Mariani Avenue  
Cupertino, California 95014  
(408) 996-1010  
TLX171-576  
076-0003

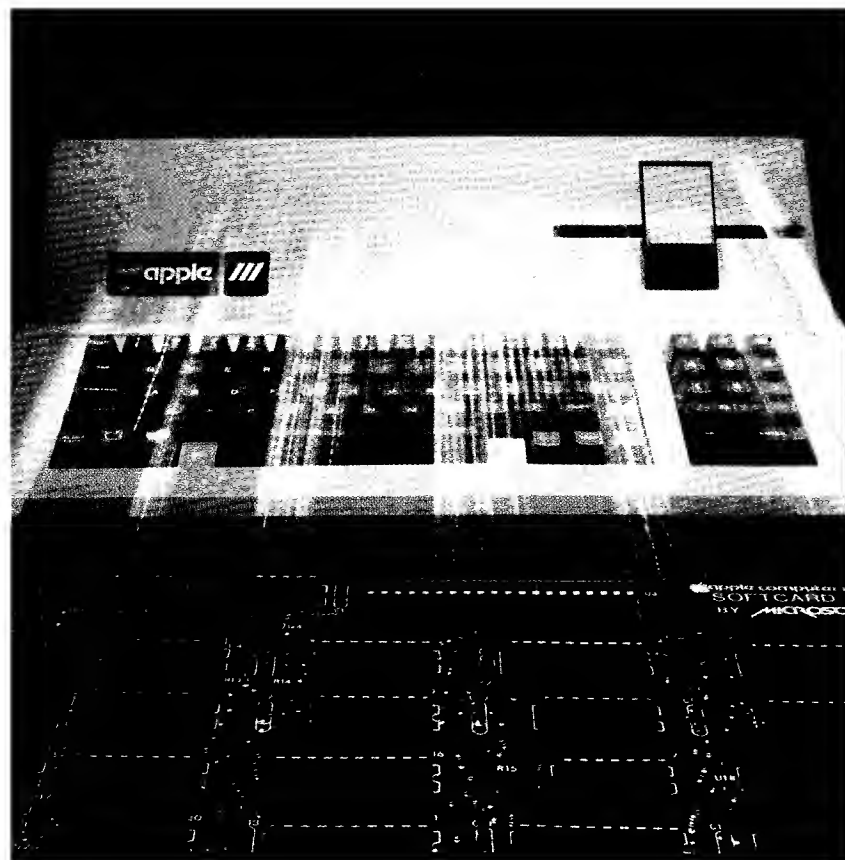

## **Notice**

---

Apple Computer, Inc., Microsoft Corporation, and Digital Research Inc. reserve the right to make improvements in the product described in this manual at any time and without notice.

## **Disclaimer of All Warranties and Liability Relating to Software**

---

APPLE COMPUTER, INC., MICROSOFT CORPORATION, AND DIGITAL RESEARCH INC. MAKE NO WARRANTIES, EITHER EXPRESS OR IMPLIED, WITH RESPECT TO THIS MANUAL OR WITH RESPECT TO THE SOFTWARE DESCRIBED IN THIS MANUAL, ITS QUALITY, PERFORMANCE, MERCHANTABILITY OR FITNESS FOR ANY PARTICULAR PURPOSE. THIS SOFTWARE IS LICENSED "AS IS." THE ENTIRE RISK AS TO ITS QUALITY AND PERFORMANCE IS WITH THE BUYER. SHOULD THE SOFTWARE PROVE DEFECTIVE FOLLOWING ITS PURCHASE, THE BUYER (AND NOT APPLE COMPUTER, INC., MICROSOFT CORPORATION, OR DIGITAL RESEARCH INC., THEIR DISTRIBUTORS, OR THEIR RETAILERS) ASSUMES THE ENTIRE COST OF ALL NECESSARY SERVICING, REPAIR, OR CORRECTIONS AND ANY INCIDENTAL OR CONSEQUENTIAL DAMAGES. IN NO EVENT WILL APPLE COMPUTER, INC., MICROSOFT CORPORATION, OR DIGITAL RESEARCH INC. BE LIABLE FOR DIRECT, INDIRECT, INCIDENTAL, OR CONSEQUENTIAL DAMAGES RESULTING FROM ANY DEFECT IN THE SOFTWARE EVEN IF THEY HAVE BEEN ADVISED OF THE POSSIBILITY OF SUCH DAMAGES. SOME STATES DO NOT ALLOW THE EXCLUSION OR LIMITATION OF IMPLIED WARRANTIES OR LIABILITIES FOR INCIDENTAL OR CONSEQUENTIAL DAMAGES, SO THE ABOVE LIMITATION OR EXCLUSION MAY NOT APPLY TO YOU.

The SoftCard™ III printed circuit board and all software and documentation in the SoftCard III package exclusive of the CP/M™ operating system are copyrighted under U.S. copyright laws by Microsoft Corporation. The CP/M operating system and CP/M documentation are copyrighted under U.S. copyright laws by Digital Research. Copyright © 1976, 1977, 1978 by Digital Research Inc. All rights reserved. (*CP/M Reference Manual* edited in part by Microsoft Corporation.)

This manual may not, in whole or part, be copied, photocopied, reproduced, translated, or reduced to any electronic medium or machine-readable form without prior consent, in writing, from copyright owners.

Copyright © Microsoft Corporation 1982  
All rights reserved.

SoftCard III is a trademark of Microsoft Corporation.  
Apple, Apple III, and the Apple logo are registered trademarks of Apple Computer, Inc.  
ProFile is a trademark of Apple Computer, Inc.  
CP/M is a registered trademark of Digital Research, Inc.  
Z80 is a registered trademark of Zilog, Inc.

**Apple III**

**SoftCard III Installation  
and Operation Manual**

# Contents

## ***Preface*** ***vii***

---

vii	How to Use the Apple SoftCard III Manuals
ix	Syntax Notation
x	Design Credits
x	Digital Research License Information

## ***1 Introduction*** ***1***

---

2	The Apple SoftCard III Concept
3	The CP/M Operating System
3	Microsoft BASIC Interpreter
5	Apple SoftCard III Utility Programs
5	Apple SoftCard III Package Contents
7	System Requirements

## Appendix A

### **Apple SoftCard III Specifications** 91

- 92 General Specifications
- 93 CP/M Operating System Specifications
  - 93 Standard CP/M Transient Programs Provided
- 93 Apple SoftCard III Utility Programs Provided
  - 94 CP/M Program Compatibility
- 94 Microsoft BASIC Interpreter Specifications

### **Index** 95

## Preface

This section contains the following information: "How to Use the Apple SoftCard III Manuals," "Syntax Notation," "Design Credits," and "Digital Research License Information."

### **How to Use the Apple® SoftCard™ III Manuals**

The SoftCard III package is documented in four manuals. The *SoftCard III Installation and Operation Manual* introduces the SoftCard III package as well as the CP/M operating system. It also describes how to install the SoftCard III circuit board and how to use the SoftCard utility programs. *Read this manual before installing the SoftCard III circuit board and the software.*

*The Microsoft BASIC Reference Manual* explains how to use the Microsoft BASIC Interpreter. It is intended for those who already know how to program BASIC. If you are new to BASIC, a recommended reading list is provided for your convenience.

The *Osborne CP/M User Guide* explains how to use the CP/M operating system with the SoftCard III System. It is particularly helpful for new CP/M users.

The *CP/M Reference Manual* is included for seasoned CP/M users. It fully documents the CP/M editor, assembler, and debugging tool.

Together these manuals provide complete documentation for using your Apple III as a CP/M computer.

The *SoftCard III Installation and Operation Manual* is divided into five chapters and one appendix:

#### Chapter 1 *Introduction*

Introduces the SoftCard III system. Also lists the package contents and equipment needed for operation.

#### Chapter 2 *Installation*

Describes how to install the SoftCard III circuit board and how to get CP/M up and running. This chapter also includes procedures for making backup copies of your Apple SoftCard III CP/M Master diskette and for configuring the CP/M environment to your system.

#### Chapter 3 *An Introduction to Apple SoftCard III CP/M*

Introduces the CP/M operating system and describes how it works with your Apple III.

#### Chapter 4 *Apple SoftCard III Utility Programs*

Explains how to use the Apple SoftCard III utility programs and what to do if an error occurs.

#### Chapter 5 *Running CP/M with ProFile*

Explains how to use CP/M with the ProFile disk drive.

#### Appendix A *Apple SoftCard III Specifications*

Lists Apple SoftCard III specifications.



Before you read this manual and install the SoftCard, read the *Apple III Owner's Guide*.

Two special symbols are used throughout this manual to draw your attention to particular items of information.



The pointing hand indicates something particularly interesting or useful.



The eye is used for points you need to be cautious about.

## **Syntax Notation**

The following notation is used throughout this manual in descriptions of command syntax:

[ ] Square brackets indicate that the enclosed entry is optional.

< > Angle brackets indicate user-entered data. When the angle brackets enclose lowercase text, you must type in an entry defined by the text; for example, <filespec>. When the angle brackets enclose uppercase text, press the key named by the text; for example, <RETURN>.

Since the Apple III displays lowercase characters, you can enter commands in lowercase. This will not affect operation.

{ } Braces indicate that you have a choice between two or more entries. At least one of the entries enclosed in braces must be chosen, unless the entries are also enclosed in square brackets (and therefore optional).

... Ellipses indicate that an entry may be repeated as many times as needed or desired.

All other punctuation, such as commas, colons, slash marks, and equal signs must be entered exactly as shown.

## ***Design Credits***

---

The Apple SoftCard III circuit board was designed for Microsoft Corporation by Burtronix of Villa Park, California.

The Apple SoftCard III system and documentation was designed and prepared for Apple Computer, Inc. by Microsoft Corporation.

## ***Digital Research License Information***

---

**IMPORTANT:** Microsoft's license with Digital Research Inc. for the CP/M operating system requires that each purchaser of the SoftCard with CP/M register with Microsoft Corporation so that records can be maintained of all CP/M owners. This requirement is made by Digital Research Inc., not by Microsoft. A postcard is enclosed for reply. The serial number requested on the card is the number stamped on the Apple SoftCard III CP/M Master diskette label. The registration card also specifies agreement to Digital Research's software license agreement. Before signing the card and returning it to Microsoft, read the software license agreement below carefully.

Digital Research  
Box 579, Pacific Grove, California, 93950

## ***Software License Agreement***

**IMPORTANT:** All Digital Research programs are sold only on the condition that the purchaser agrees to the following license.

**READ THIS LICENSE CAREFULLY.** If you do not agree to the terms contained in this license, return the packaged diskette UNOPENED to your distributor and your purchase price will be refunded. If you agree to the terms contained in this license, fill out the REGISTRATION information and RETURN by mail to MICROSOFT CORPORATION.

DIGITAL RESEARCH agrees to grant and the Customer agrees to accept on the following terms and conditions nontransferable and nonexclusive licenses to use the software program(s) (Licensed Programs) herein delivered with this agreement.

**TERM:** This agreement is effective from the date of receipt of the above-referenced program(s) and shall remain in force until terminated by the Customer upon one month's prior written notice, or by Digital Research as provided below.

Any license under this Agreement may be discontinued by the Customer at any time upon one month's prior written notice. Digital Research may discontinue any license or terminate this Agreement if the Customer fails to comply with any of the terms and conditions of this Agreement.

**LICENSE:** Each program license granted under this Agreement authorizes the Customer to use the Licensed Program in any machine readable form on any single computer system (referred to as System). A separate license is required for each System on which the Licensed Program will be used.

This Agreement and any of the licenses, programs or materials to which it applies may not be assigned, sublicensed or otherwise transferred by the Customer without prior written consent from Digital Research. No right to print or copy, in whole or in part, the Licensed Programs is granted except as hereinafter expressly provided.

## ***Permission to Copy or Modify Licensed Programs***

The Customer shall not copy, in whole or part, any Licensed Programs which are provided by Digital Research in printed form under this agreement. Additional copies of printed materials may be acquired from Digital Research.

Any Licensed Programs which are provided by Digital Research in machine readable form may be copied, in whole or in part, in printed or machine readable form in sufficient number for use by the Customer with the designated System, to understand the contents of such machine readable material, to modify the Licensed Program as provided below, for back-up purposes, provided, however, that no more than five (5) printed copies will be in existence under any license at any one time without prior written consent from Digital Research. The Customer agrees to maintain appropriate records of the number and location of all such copies of Licensed

Programs. The original, and any copies of the Licensed Programs, in whole or in part, which are made by the Customer shall be the property of Digital Research. This does not imply, of course, that Digital Research owns the media on which the Licensed Programs are recorded. The Customer may modify any machine readable form of the Licensed Programs for his own use and merge it into other program material to form an updated work, provided that, upon discontinuance of the license for such Licensed Program included in an updated work, it shall be used only if on the designated System and shall remain subject to other terms of this Agreement.

The Customer agrees to reproduce and include the copyright notice of Digital Research on all copies, in whole or in part, in any form, including partial copies of modifications, of Licensed Programs made hereunder.

### *Protections and Security*

The customer agrees not to provide or otherwise make available any Licensed Program including but not limited to program listings, object code and source code, in any form, to any person other than Customer or Digital Research employees, without prior written consent from Digital Research, except with the Customer's permission for purposes specifically related to the Customer's use of the Licensed Program.

### *Discontinuance*

Within one month after the date of discontinuance of any license under this Agreement, the Customer will furnish Digital Research a certificate certifying that through his best effort, and to the best of his knowledge, the original and all copies, in whole or in part, in form, including partial copies in modifications, of the Licensed Program received from Digital Research or made in connection with such license have been destroyed, except upon written authorization from Digital Research. The Customer may retain a copy for archive purposes.

### *Disclaimer of Warranty*

Digital Research makes no warranties with respect to the Licensed Programs. The sole obligation of Digital Research shall be to make available all published modifications or updates made by Digital Research to Licensed Programs which are published within one (1) year from date of purchase, provided Customer has returned the Registration Card delivered with the Licensed Program.

### *Limitation of Liability*

THE FOREGOING WARRANTY IS IN LIEU OF ALL OTHER WARRANTIES, EXPRESSED OR IMPLIED, INCLUDING, BUT NOT LIMITED TO, THE IMPLIED WARRANTIES OF MERCHANTABILITY AND FITNESS FOR A PARTICULAR PURPOSE. IN NO EVENT WILL DIGITAL RESEARCH BE LIABLE FOR CONSEQUENTIAL DAMAGES EVEN IF DIGITAL RESEARCH HAS BEEN ADVISED OF THE POSSIBILITY OF SUCH DAMAGES.

GENERAL: If any of the provisions, or portions thereof, of this Agreement are invalid under any applicable statute or rule of law, they are to that extent to be deemed omitted.

## ***Introduction***

- 2 The Apple SoftCard III Concept
- 3 The CP/M Operating System
- 3 Microsoft BASIC Interpreter
- 5 Apple SoftCard III Utility Programs
- 5 Apple SoftCard III Package Contents
- 7 System Requirements



# 1

## *Introduction*

### *The Apple SoftCard III Concept*

The Apple SoftCard III System is a revolutionary concept in micro-computers. It is a "computer within a computer" that greatly enhances the capabilities of your Apple III computer. The Apple SoftCard III circuit board actually contains a Z80<sup>®</sup> microprocessor. This allows you to run software written for Z80 and 8080-based microcomputers on your Apple III.

The Apple SoftCard III itself is a peripheral interface board that plugs into one of the four peripheral expansion slots in the back of the Apple III. It contains a Z80 microprocessor with interface circuitry that utilizes the Apple III memory and I/O bus. Once the Apple SoftCard III circuit board is installed, you can operate your Apple III in either 6502 mode (using the 6502 microprocessor) or CP/M mode (using the Z80 microprocessor). When you are in 6502 mode, the Apple SoftCard III will not affect the operation of your Apple III.

In CP/M mode, you can run both the CP/M operating system and Microsoft BASIC Interpreter. Both are included in the Apple SoftCard III package.

### *The CP/M Operating System*

Next to the circuit board itself, the CP/M operating system is the most important key to running the wide variety of available CP/M software on the Apple III. Version 2.20 of the CP/M operating system is included in the Apple SoftCard III package.

Unless you have the software to make it useful, a computer is nothing more than a "black box" that draws power. To run programs, an operating system is needed. CP/M is an operating system designed for use with 8080 and Z80 microprocessors. It is comprised of many small programs whose collective function is to write information to and retrieve information from storage media, such as disk drives. CP/M has been adapted to run on almost all 8-bit computers which use the 8080 or Z80 families of microprocessors.

The Apple SoftCard III makes all the modifications necessary to make CP/M run on the Apple III computer. With Apple SoftCard III, Apple III users can take advantage of the CP/M operating system and the extensive library of high-level languages and application software which have been written for CP/M.

In addition to supporting a wide variety of software, CP/M offers several convenient features. These include easy interface to machine-language programs; faster disk I/O access; simple file transfer; and "wild card" file naming conventions that allow you to refer to multiple files with one name. CP/M also includes several transient programs that perform utility functions.

### *Microsoft BASIC Interpreter*

Microsoft BASIC Interpreter (Version 5.2) is also included in the Apple SoftCard III package. Microsoft BASIC is the most widely implemented BASIC in use today. Standard Microsoft BASIC features include:

- 16-digit precision: Three variable types (fast two-byte true integer variables, single precision variables, and double precision variables) provide 16-digit precision.

- **EDIT commands:** Extensive editing commands let you edit individual program lines easily and efficiently, without re-entering the entire line.
- **Built-in disk I/O statements:** Provide fast and powerful disk I/O access.
- **PRINT USING:** Greatly enhances programming convenience by making it easy to format output. Includes asterisk fill, floating dollar sign, scientific notation, trailing sign, and comma insertion.
- **WHILE/WEND:** Gives BASIC a more structured organization. By putting a WHILE statement in front of and a WEND statement at the end of a loop, you can continuously execute the loop as long as a given condition is true.
- **AUTO and RENUM:** AUTO generates a line number automatically after every carriage return. RENUM automatically rennumbers lines in user-specified increments.
- **CHAIN and COMMON:** Call in another BASIC program from disk or diskette and pass variables to it.
- **IF ... THEN ... ELSE:** Extends the IF statement to provide handling for the negative case of IF.
- **Added operators:** Provides AND, OR, XOR, EQV, IMP, and MOD.
- **Expanded user-defined functions:** Can have multiple parameters.

## ***Apple SoftCard III Utility Programs***

In addition to the standard CP/M transient programs, the Apple SoftCard III package includes utility programs that automatically perform certain time-consuming tasks, such as disk formatting and file transfer. The Apple SoftCard III utility programs allow you to:

Format and copy a diskette with the COPY program.

Transfer SOS files to your CP/M diskette with the SOSXFER program.

Configure the Apple III CP/M environment to your particular system device configuration with the CONFIG program.

Display disk files in your directories in alphabetical order with the CAT program.

Transfer files from one diskette to another diskette in a single drive system with the MFT program.

Set and display the time from the Apple III clock (if installed) with the TIME program.

Create turnkey program diskettes with the TURNKEY program.

## ***Apple SoftCard III Package Contents***

---

Your Apple Softcard III package should include:

One Apple SoftCard III printed circuit board

One SOS-CP/M Utilities diskette, which includes the Volume Configuration Program

One Apple SoftCard III CP/M Master diskette, which includes the CP/M operating system and the following files:

ASM.COM	DUMP.ASM	PIP.COM
BOOT.COM	DUMP.COM	SOSXFER.COM
CAT.COM	ED.COM	STAT.COM
CONFIG.COM	LOAD.COM	SUBMIT.COM
COPY.COM	MBASIC.COM	TIME.COM
DDT.COM	MFT.COM	TURNKEY.COM
DRIVER.SOS	PATCH.COM	XSUB.COM

Four manuals:

*Apple SoftCard III Installation and Operation Manual*  
*Microsoft BASIC Reference Manual*  
*CP/M Reference Manual*  
*Osborne CP/M User Guide*

Disk drive labels

A Warranty Registration Card

An Apple III User Input Report Form

If you are missing any of these items, contact the Apple dealer from whom you purchased the Apple SoftCard III package.

Your package also includes the Digital Research License Agreement Card. Fill out the Warranty Registration Card and the Digital Research License Agreement Card and mail them immediately.



Before you open your diskette package, read the Digital Research Software License Agreement. If you agree with the terms of the agreement, fill out the license registration card and mail it immediately.

## **System Requirements**

To use your Apple SoftCard III system successfully, you will need the following equipment:

1. A 128K Apple III computer
2. An Apple SoftCard III printed circuit board
3. Disk drives: only the built-in drive is needed, but two drives are recommended. The 5-megabyte ProFile™ disk drive is supported.
4. A monitor
5. At least three blank diskettes
6. The Apple SoftCard III CP/M Master diskette
7. The SOS-CP/M Utilities diskette
8. The (Apple III) System Utilities diskette

## *Installation*

- 10 Apple SoftCard III Installation Procedure
- 15 Loading Apple SoftCard III CP/M
- 16 Backing Up the Apple SoftCard III Master Diskette
  - 16 Making Backup Copies With a Single Drive System
  - 17 Making Backup Copies With a Multiple Drive System
- 19 I/O Configuration
  - 19 Apple III I/O Communication
  - 20 Apple SoftCard III CP/M I/O Communication
  - 21 Changing the I/O Configuration

## 2 Installation

This chapter provides step-by-step instructions for installing the Apple SoftCard III circuit board. We recommend you read all of the instructions first to acquaint yourself with the overall procedure. Then, perform each step with care exactly as described.

### Handling Precautions

Always handle the computer and its components carefully, as you would any electrical or electronic device. Removing or replacing parts while the power is on can damage the computer or create a shock hazard.

Hold the Apple SoftCard III (or any other peripheral board) by its edges to avoid contaminating it with oil from your hands. Be especially careful to avoid touching the gold edge-connector on the bottom of the board.

### Apple SoftCard III Installation Procedure

The Apple SoftCard III circuit board mounts in any peripheral connector slot in the back of the Apple III computer (see Figure 1). However, we recommend slot 2 for Apple SoftCard III installation. Use the following procedure to install the Apple SoftCard III circuit board.



You will need a medium flat-blade screwdriver to remove and reinstall the Apple III's top cover.

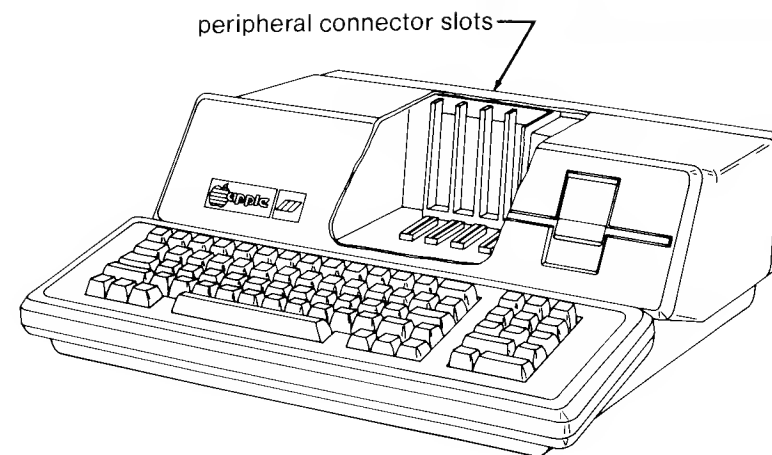

**Figure 1**

1. Set the Apple III power switch to the OFF position (see Figure 2).

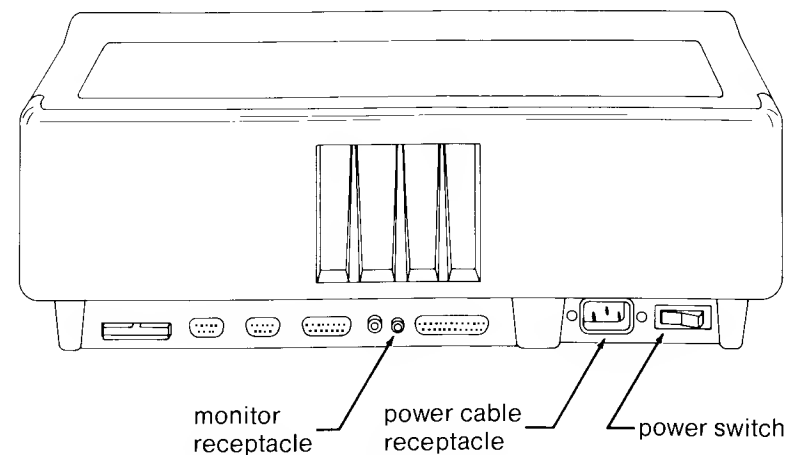

**Figure 2**

2. Turn all external power switches to OFF (display monitor, printer, etc.).
3. Disconnect all power cables from wall outlets.

4. Disconnect and remove all other cables from the back of the computer.
5. Ensure that there is nothing on the top cover of the computer.
6. Tilt the Apple III on its back. Use the screwdriver to loosen (a quarter turn in a counterclockwise direction) the captive screws holding the Apple III's top cover in place. See Figure 3 for captive screw locations.

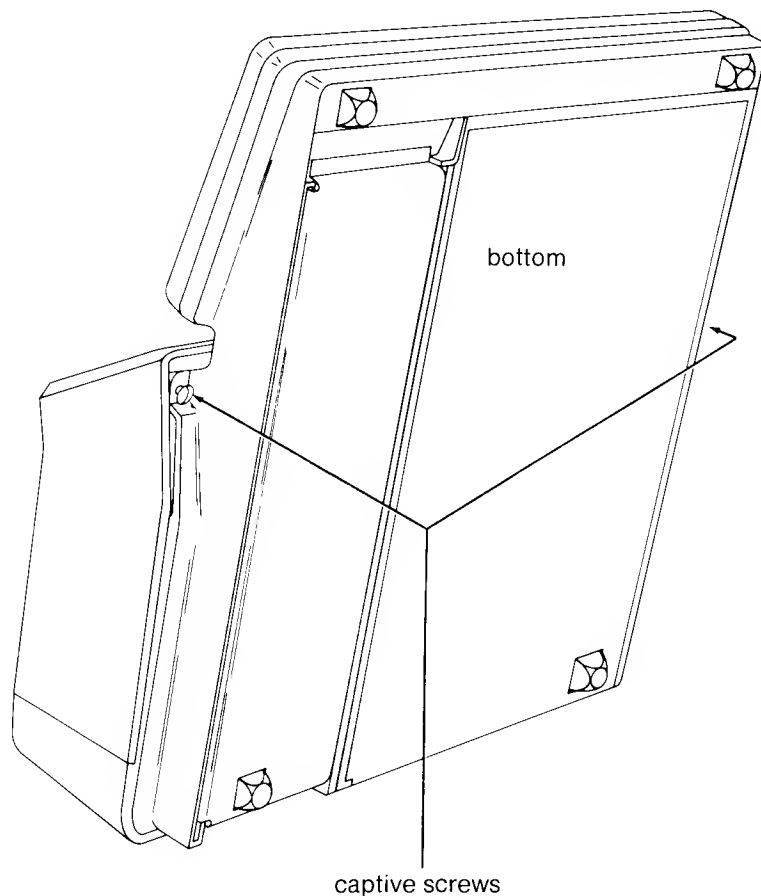

Figure 3

7. Gently lower the Apple III back down. Slide the top cover slightly forward. Then, lift it straight up and place aside.
8. Locate peripheral connector slot 2 (second slot from the left). This is the recommended slot, although the Apple SoftCard III circuit board will function from any one of the peripheral connector slots. Remove the dummy card (if present) from slot 2 by gently rocking it toward the keyboard and then pulling straight up. To make removal easier, there is a hole drilled in the top of each card. You can insert a screwdriver into the hole and pry the card up, using the side of the card for leverage. Now you are ready to install the Apple SoftCard III circuit board.
9. Align the Apple SoftCard III circuit board in slot 2 (the component side should face the right side of the chassis) so that the card edge-connector faces the back of the chassis and the front of the card is in the rear guide slot. Ensure that the metal bracket on the Apple SoftCard III circuit board is in the rear guide slot. Use Figure 4 as a guide.

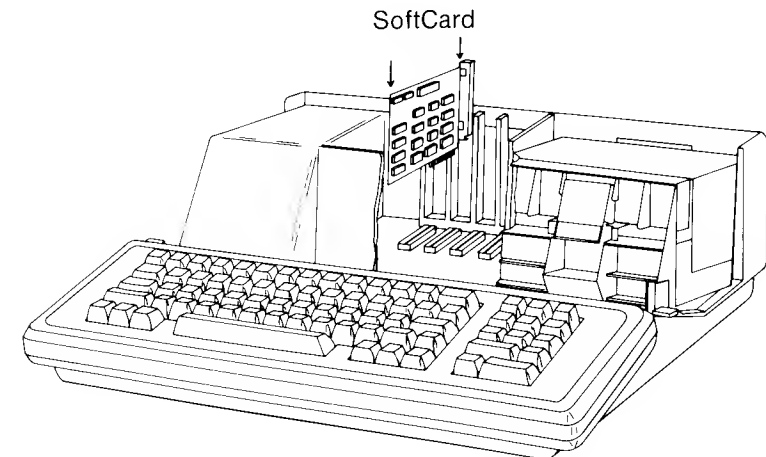

Figure 4

10. Press the Apple SoftCard III circuit board down into the peripheral connector slot using steady, but firm pressure. When the top of the metal bracket is flush with the top of the rear guide slot, the Apple SoftCard III circuit board is in place.
11. Place the top cover on the top of the Apple III so the back of the cover is flush with the back of the computer and the holes on the underside of the cover front fit over the two captive screws.
12. Tilt the Apple III slightly back on its side.
13. Using a short, flat-blade screwdriver, tighten the two captive screws by pushing them in and turning them each approximately one-quarter turn in a clockwise direction.
14. Reinstall the peripheral cables removed in Step 4.
15. Reinstall the power cables to the Apple III and peripheral devices.
16. Set power switches of external devices (monitor, printer, etc.) to ON.

Since CP/M uses letters to identify disk drives, we suggest that you apply the labels that came with the Apple SoftCard III package to the front of each disk drive as indicated:

The built-in drive is labeled drive A:

The first external drive is labeled drive B:

Each successive drive is labeled with the next successive letter.

Now your Apple SoftCard III system is ready for use. Checkout of the system consists of bringing up CP/M and using it. But, before you turn on your Apple III, please read the sections on "Loading Apple SoftCard III CP/M" and "Backing Up the Apple SoftCard III Master Diskette." It is possible to damage your diskettes if you don't follow the information in these two sections.

## ***Loading Apple SoftCard III CP/M***

---

Loading Apple SoftCard III CP/M is easy. Simply insert the Apple SoftCard III CP/M Master diskette into the built-in drive and set the Power switch to ON. (CP/M diskettes are inserted into the Apple III disk drives the same way SOS diskettes are inserted. The label is up and the write-protect notch is to the left.) This automatically boots the system. After a few seconds, the screen displays:

```
Apple SoftCard /// CP/M
      56K version 2.20
(C) 1982 Microsoft Corp.
```

```
A>
```

The A> prompt indicates that CP/M is ready to accept a command.

As noted in the previous paragraphs, CP/M uses letters to identify disk drives. The A> indicates that all disk operations will be performed from drive A: unless commanded otherwise (more about that to come).

To see that CP/M is really working, type

```
DIR
```

and press <RETURN> to display the names of all the programs on your Apple SoftCard III CP/M Master diskette. (The DIR command is explained in Chapter 3 of this manual.)

Before you do proceed, you should make backup copies of your Apple SoftCard III CP/M Master diskette, as discussed in the next section.



Throughout the rest of this manual, the Apple SoftCard III CP/M Master diskette is referred to as the Apple SoftCard III Master diskette.

## ***Backing Up the Apple Softcard III Master Diskette***

Making backup copies of your Apple SoftCard III Master diskette is a simple, one-step process which uses the COPY utility program. (The COPY utility program is fully documented in Chapter 4 of this manual.) Since diskettes have a limited life span, we recommend that you make at least two backup copies and use one of them as your working Master diskette (especially if you plan to make changes to suit your system configuration). Store your original Master and any extra copies in a safe, dry place, free from magnetic interference.

If you make a mistake when typing a command, use the ← key to backspace and correct it. A description of CP/M editing commands may be found in Chapter 3 of this manual.

Use the procedure designed for your system configuration (single drive or multiple drive) to make backup copies of the Apple SoftCard III Master diskette.

### ***Making Backup Copies with a Single Drive System***

Make a backup of your Apple SoftCard III Master diskette as follows:

1. Insert the Apple SoftCard III Master diskette in drive A: (the built-in drive) and type:

```
COPY A:=A:
```

After a few seconds, the screen displays:

```
Apple SoftCard /// CP/M
Disk Backup Program
(C) 1982 Microsoft Corp.
```

```
Insert SOURCE      disk & press RETURN
```

2. Leave the Master diskette in drive A: and press <RETURN>. The COPY program responds by displaying:  
 Insert DESTINATION disk & press RETURN
3. Remove the Apple SoftCard III Master diskette and insert a blank diskette into drive A: and press <RETURN>. The computer will copy a portion of the diskette. It then prompts you with:

```
Insert SOURCE      disk & press RETURN
```

This is repeated until the entire diskette is copied. When the copy process is complete, the screen displays:

```
Operation complete
```

```
Again (Y/N)?
```

You now have a backup copy of your Apple SoftCard III Master diskette.

4. If you wish to make additional copies at this time, type <Y> to repeat the copy process.

If you do not want to make another copy, type <N>. The screen displays:

```
Insert CP/M System disk into drive A:
Press RETURN
```

Since you already have a copy of your Apple SoftCard III Master diskette in the drive, simply press <RETURN>. This will return you to CP/M command level as denoted by the A> prompt.

### ***Making Backup Copies with a Multiple Drive System***

If you have a multiple drive system, make a backup of your Apple SoftCard III diskette as follows:

1. Insert your Apple SoftCard III Master diskette into drive A: (the built-in drive) and type:

```
COPY B:=A:
```



After a few seconds, the screen displays:

```
Apple SoftCard /// CP/M
Disk Backup Program
(C) 1982 Microsoft Corp.
```

```
Insert SOURCE      disk into drive A:
Insert DESTINATION disk into drive B:
```

```
Press RETURN to begin
```

2. Insert a blank diskette into drive B:. When the copy process begins, the screen displays:

```
Copying . . .
```

When the copy process is complete, the screen displays the prompts:

```
Operation complete
```

```
Again (Y/N)?
```

You now have a backup copy of your Apple SoftCard III Master diskette.

3. If you want to make another copy, press <Y>.

When you are through copying diskettes, press <N>. The program responds with:

```
Insert CP/M System disk into drive A:
Press RETURN
```

Remove the Apple SoftCard III Master diskette and store it in a safe, dry place.

4. Remove the copy you have just made from drive B: and insert it into drive A:. Press <RETURN> to exit to CP/M command level.



If you have problems that are not immediately identifiable as hardware or software-related, use a backup copy to test your system. That way you do not risk destroying your Apple SoftCard III Master diskette.

## I/O Configuration

Configuring CP/M to communicate with specific I/O devices is the last step in installing the Apple SoftCard III System. This section explains how to configure CP/M to your system.

Your Apple SoftCard III CP/M system is initially configured to communicate with the following types of I/O devices:

The Apple III keyboard and monitor

Four floppy disk drives

A Silentype printer

A serial printer

If your system includes only these I/O devices, there is no need to change the I/O configuration; therefore, we recommend that you skip this section and read the next chapter. However, if you have other or different I/O devices in your system, continue reading this section.

### **Apple III I/O Communication**

Under SOS (Sophisticated Operating System), the Apple III communicates with I/O devices (the monitor, disk drives, etc.) through *device drivers*. A device driver is a program that provides the necessary translation code for transactions between the operating system and the I/O device "hardware." Each device driver is written for a particular type of I/O device.

There are two types of devices in SOS: block devices and character devices. Block devices are external devices for storage and retrieval of data. Disk drives are block devices. Character devices are devices for I/O communication. The keyboard and monitor are character devices.

When you first receive your Apple III, you must use the SOS System Configuration Program (SCP) to load the needed device drivers into a file called SOS.DRIVER on your SOS boot diskettes. This allows SOS to load the right device drivers each time you boot the system.

## Apple SoftCard III CP/M I/O Communication

Apple SoftCard III CP/M is designed to communicate with both types of devices through the standard SOS device drivers. However, CP/M cannot refer to the SOS drivers by name. CP/M has its own device names, collectively called logical devices. There are four logical devices that can be directly accessed from CP/M:

CON:	The system console device. All keyboard and screen I/O communication is through this device.
PUN:	Auxiliary output device. An output only device that may be used for modems, PROM programmers, etc.
RDR:	Auxiliary input device. An input only device that may be used in conjunction with PUN:.
LST:	The system printer device. All printer output is to this device.

Each of the four logical devices can be assigned to one of four CP/M physical devices, as shown in the following list.

CON:	PUN:	RDR:	LST:
CO1:	PU1:	RD1:	LS1:
CO2:	PU2:	RD2:	LS2:
CO3:	PU3:	RD3:	LS3:
CO4:	PU4:	RD4:	LS4:



Apple SoftCard III CP/M physical device names differ from those in other CP/M versions. In addition, there are fewer device types available. These changes ensure compatibility with SOS.

Each of the CP/M physical devices can be assigned to a SOS character device driver. For example, the CP/M physical device CO1: is assigned to the SOS .CONSOLE device.

CP/M physical-to-logical device assignments are changed with the CONFIG utility program and the STAT transient program. In addition, CONFIG also changes the CP/M physical device-to-SOS device driver assignments. These changes, however, take effect only after a CP/M cold start.

Since the Apple SoftCard III System communicates with I/O devices through the Apple III I/O bus, CP/M must use SOS device drivers as part of its I/O communications interface. Each physical device driver in Apple SoftCard III CP/M is written to communicate with a specific type of SOS device driver. Thus, CP/M communicates with I/O devices through the SOS device drivers.

Each time you boot CP/M, a set of SOS device drivers (from a file called DRIVER.SOS on the Apple SoftCard III Master diskette) is loaded into memory. This ensures that the right device drivers are loaded into memory each time you boot the system.

## Changing the I/O Configuration

Whenever a SOS device driver is changed, the CP/M device assignments must also be changed. This involves three separate steps:

1. SOS device drivers are changed with the SOS System Configuration Program.
2. The file containing the device drivers (SOS.DRIVER) is transferred to the CP/M file DRIVER.SOS with the SOSXFER program.
3. New CP/M logical-to-physical device assignments are made with the CONFIG utility program.

If you need to change I/O assignments, use the following procedure to change device driver assignments.

## General I/O Configuration Procedure



The following provides only general procedures for changing the I/O configuration. See the references listed in each step for specific instructions.

1. Insert the Apple III System Utilities diskette into the built-in drive and boot the system.
2. When the menu appears on the screen, select the System Configuration Program (SCP) by pressing <S> and <RETURN>.
3. Use the appropriate procedure to change each SOS device driver. The procedures are explained in "Configuring Your System" in the *Apple III Owner's Guide* and in the *Apple III Standard Device Drivers Manual*.



If you are adding a ProFile disk drive to your system, use the Apple III Volume Configuration Utility on your SOS-CP/M Utilities diskette to allocate disk space on ProFile. (See "Setting Up ProFile for CP/M" in Chapter 5 of this manual.)

4. When a new system has been generated, use the SOSXFER utility program to copy the SOS.DRIVER file onto a copy of the Apple SoftCard III Master diskette. (See "SOSXFER" in Chapter 4 of this manual.)
5. Once the SOS.DRIVER file has been loaded (renamed to DRIVER.SOS on the Apple SoftCard III Master diskette copy) use the CONFIG utility program to change the necessary CP/M device assignments. (See "CONFIG" in Chapter 4 of this manual.)
6. Reboot the system to load the device assignments into the Apple SoftCard III CP/M environment.

## An Introduction to Apple SoftCard III CP/M

25	CP/M and the Apple III
25	The Apple III CP/M Keyboard
26	Line Editing Commands
27	Output Control Commands
28	CP/M Warm Start and Cold Start
28	CP/M Diskettes
30	CP/M File Naming Conventions
33	CP/M Built-In Commands
34	DIR
34	TYPE
35	ERA
35	USER
36	REN
36	<d:>
36	SAVE
39	CP/M Transient Programs
40	ASM
41	DDT
41	DUMP
41	ED
42	LOAD
42	PIP
42	STAT
43	SUBMIT
43	XSUB
44	CP/M Error Messages
44	BDOS ERR ON X: BAD SECTOR
45	BDOS ERR ON X: R/O
45	BDOS ERR ON X: FILE R/O
45	BDOS ERR ON X: SELECT

# 3

## ***An Introduction to Apple SoftCard III CP/M***

This chapter introduces CP/M as it is implemented on the Apple III computer through the Apple SoftCard III System. If you are new to CP/M, we strongly recommend you read the *Osborne CP/M User Guide* after completing this chapter.

CP/M, like SOS, is an operating system. An operating system is a collection of programs which interface “software” (programming languages and application programs) and the computer “hardware” (the physical components that make up your computer). An operating system also coordinates communication between the computer and the various I/O devices (the monitor, disk drives, printers, etc.). CP/M was written to perform these functions on any Z80/8080-based computer.

An operating system requires instructions on which functions it must perform and when to perform them. Your commands provide these instructions to the operating system. CP/M commands are divided into two categories: built-in commands and transient programs (also called transient commands).

*Built-in commands* are commands that are loaded into memory when CP/M is booted. They are always present whenever you are running CP/M. Hence, the name, “built-in.” Built-in commands perform tasks such as displaying the contents of a file or a directory of disk files, renaming and erasing files, and saving the contents of memory on diskette.

*Transient programs* are programs that are loaded into memory from the diskette before being executed. In general, they perform more complicated tasks than built-in commands, such as transferring and copying files and tasks associated with assembly language programming.

Most CP/M commands and transient programs (with the exception of a few, such as REN) are extensible. That is, they may be extended semantically to include additional arguments or operations. For example, the DIR command could include an argument for a list of specific file types (such as BASIC files) and would have the argument “\*.BAS”. This instructs CP/M to display only those files with the extension of .BAS (BASIC files).

### ***CP/M and the Apple III***

---

In any operating system, there are several key commands and functions that are vital to operating the computer. You need to know how to access data from memory and what the functions of the keys on the keyboard are. You also need to know what to do if an error occurs. In this section, we will describe the special functions that some of the keys have and provide general information you will need for using CP/M.

### ***The Apple III CP/M Keyboard***

Several editing keys work differently with CP/M than with SOS. The <RESET> key is disabled under CP/M (<CONTROL-RESET>, however, functions the same as in SOS). The backspace key (←) deletes the character as it moves over it, and the forward arrow key (→) produces a CONTROL-U function (a pound sign (#) and a carriage return/linefeed sequence). The up arrow key (↑) produces a CONTROL-K function, and the down arrow key (↓) gives the same results as pressing the <RETURN> key. In addition, the <ESCAPE> key cursor movement/editing features are not supported.

## Line Editing Commands

CP/M supports several line editing commands that allow you to edit a CP/M command line or input to CP/M transient programs and Apple SoftCard III utility programs. All line editing commands are executed through control characters. Control characters (denoted by "CONTROL-") are typed by first pressing the <CONTROL> key and holding it down while you type the indicated character. Do not press <RETURN> after typing a control character. Table 1 lists the control characters associated with line editing commands.

Key	Function
←	Backspaces one character position. The backspace key deletes characters as the cursor passes over them.
CONTROL-E	Moves the cursor to the beginning of the next line. However, the line is not terminated until <RETURN> is pressed. (Note: The carriage return/linefeed sequence generated by CONTROL-E is not entered into a line, but only sent to the console.)
CONTROL-H	Same as the backspace key (←).
CONTROL-J	Terminates input (linefeed). Same as the down arrow key (↓).
CONTROL-M	Same as <RETURN>.
CONTROL-R	Redisplays the current line.
CONTROL-U	Deletes the line from the input buffer and sends a carriage return/line feed sequence to the console. The line is still displayed, but is terminated with a pound sign(#). Same as the forward arrow key (→).

CONTROL-X	Backspaces and deletes the line.
RUBOUT	Deletes and echoes the last character. (Requires a CONTROL-SHIFT \ sequence since RUBOUT doesn't exist.)

**Table 1. Line Editing Commands**



You can also use the Apple III standard console control keys (e.g., CONTROL-5, -6, -7, -8, and -9), as listed in "Appendix" in the *Apple III Standard Device Drivers Manual*.

There are other important control characters that can be used to perform various functions. These are discussed in the following section.

## Output Control Commands

Two control characters control character output to the monitor screen or printer. They are:

Control Character	Function
CONTROL-S	Suspends character output to the terminal. Program execution and character output resume when any character is typed.
CONTROL-P	Sends all character output to the line printer as well as the monitor screen. This "printer echo" mode remains in effect until the next CONTROL-P is typed or a CP/M warm start is performed. (See the next section.)

**Table 2. Output Control Commands**



CONTROL-P is only accepted when console input is requested.

## **CP/M Warm Start and Cold Start**

CONTROL-C, when typed as the first character of a line, performs a CP/M *warm start*. A warm start reloads the CP/M operating system (the built-in commands, I/O communication routines, and the command system) into memory. This ensures that the CP/M operating system loaded into memory is in working order. The program and data entered previously are left intact. Warm starts can only be performed when a CP/M system or boot diskette (described in the next section) is in drive A:. Note that none of the transient programs or utility programs are loaded into memory during a warm start.

A *cold start* erases the contents of memory and loads in the CP/M operating system. All routines are initialized and the default I/O configuration is in effect. As with the warm start, no transient programs or utility programs are loaded into memory.

A cold start is performed in one of three ways:

1. Turning the power on when a CP/M boot diskette is in drive A:.
2. Pressing <CONTROL-RESET> when a CP/M boot diskette is in drive A:.
3. Typing BOOT when a copy of the Apple SoftCard III Master diskette is in drive A:.



If you are using a ProFile as drive A:, see "Changing the ProFile Drive Assignment" in Chapter 5 for more information about cold starts.

## **CP/M Diskettes**

There are three types of CP/M diskettes: system diskettes, system boot diskettes, and data diskettes. The type you use depends on your system configuration and your application.

A *CP/M system diskette* is a diskette that contains the CP/M operating system and can be loaded into memory with a warm start from drive A:. System diskettes contain CP/M built-in commands and I/O communication routines, but none of the CP/M transient programs or Apple SoftCard III utility programs.

*CP/M system boot diskettes* are system diskettes that can be loaded into memory with a cold start. System boot diskettes also contain the DRIVER.SOS file, which is needed for a CP/M cold start. This is only a minimum requirement for a system boot diskette. You may add other programs onto a system boot diskette, as desired. The Apple SoftCard III Master diskette is a good example of a system boot diskette.

A *data diskette* is for storage of CP/M programs and data files only. The CP/M operating system is not included on data diskettes. Therefore, data diskettes have an additional 12K bytes of disk space available. Consequently, data diskettes cannot be used in drive A:. (CP/M loads from drive A: when a warm start is executed.) This precludes the use of data diskettes on single drive systems.

Whenever you change diskettes, you must inform CP/M that you have done so. Specific diskette directory information is stored in memory at all times. This information is used to allocate space on the diskette. When you change diskettes, this information must be replaced with the directory information of the newly inserted diskette.

To let CP/M know that you have changed diskettes, perform a warm start by typing CONTROL-C. This updates the directory information in memory.

If you don't type CONTROL-C after changing diskettes and a WRITE operation is attempted to the changed diskette, the computer displays

BDOS ERR ON d:FILE R/O

(where d: is a disk drive A:-D: and R/O stands for Read Only). If you receive this error message, press <RETURN>. This performs a warm start and returns you to the CP/M A> prompt.

No error results if you attempt a READ operation from the changed diskette. Operation continues.

## ***CP/M File Naming Conventions***

Data stored on disks or diskettes is organized into files. Operating systems use file specifications to keep track of where information is stored and the type of information that is stored.

CP/M file naming conventions differ from SOS file naming conventions. CP/M disk files are accessed by their file specification or *filespec*, for short. File specifications are of the form:

[<disk drive identifier>:]<filename>[.<extension>]

The filespec consists of three components: the disk drive identifier, a filename, and a filename extension. A "shorthand" form of a file specification is

[d:]<filename>[.ext]

where [d:] is the disk drive identifier, <filename> is the filename, and [.ext] is the filename extension. Either form can be used to represent a file specification. The following paragraphs describe the components of the file specification.

### ***Disk Drive Identifier***

The optional disk drive identifier is a one letter code (A-D) followed by a colon (:). Disk drive identifiers tell CP/M where to look for the file. If no disk drive identifier is given, CP/M looks for the specified file on the default or currently logged drive.

The *currently logged drive* is the disk drive that you are currently working from. When you see the A> prompt, drive A: is the disk drive that will be accessed when you give a command without a disk drive identifier. It also means that you are at system *command level*.

### ***Filename***

*Filenames* are the names of disk files. A filename is the only required parameter of a file specification. A filename can be from one to eight letters in length and can consist of both uppercase and lowercase characters. The filename must start with a letter; numbers and special characters are not allowed. The filename may be followed by a period and a three character extension.

Some examples of valid CP/M filenames:

A:MAILLIST Refers to the file MAILLIST on drive A:.

R Refers to the file R on the currently logged drive. Notice that this filename has only one letter.

B:BARBAR Refers to the file BARBAR on drive B:.

### ***Filename Extension***

The three-character *filename extension* usually reflects the internal format of a file (the type of information in the file). You can also use filename extensions to denote different versions of a file. For example, FNAME.1 could be the first version of the program FNAME. If you create a second version (or revise the first), you can save both versions by giving them different filename extensions (FNAME.1 and FNAME.2).

There are many common filename extensions that represent different types of files. We already mentioned two of them (BAS for BASIC files and PRN for print listing files). The most important of these common extensions is COM, which stands for COMMAND. Any file with a COM extension is a transient command type file and can be run by simply typing its name (without the .COM extension). Other common extensions are HEX, ASM, and PRN, which are used by the CP/M assembler program ASM.

## Wild Card Filename Specifications

File specifications can also refer to more than one file at a time. This is done with "wild card" filename characters. A question mark in a filename is a "wild card" character; that is, it matches any single or null character in that position when you search the directory for the filename match. An asterisk ("\*") is another "wild card" character; \* matches any string of characters. For example,

B:TEMP.???

or

B:TEMP.\*

refer to both TEMP.OLD and TEMP.NEW on drive B:, if they exist.

More examples of "wild card" file specifications:

A:*.COM	Refers to all files on drive A: with an extension of .COM.
B:*. *	Refers to all files on drive B:.
B:?????????.???	Exactly the same as B:*. * above.
DUMP.*	Refers to all files on the currently logged drive beginning with the filename "DUMP".
C*.*	Refers to any file on the currently logged drive beginning with the letter "C" and containing any extension.
*O.*	This is the same as *. *. The asterisk (*) is an abbreviation for a string of question marks (?). If an asterisk is included as part of the string, CP/M ignores all characters to the right of the asterisk and treats the whole string as a wild card character. Note the difference between this example and the next example.

?O??????.*	Refers to all files with "O" as the second letter of the filename on the currently logged drive.
------------	--

## CP/M Built-in Commands

CP/M built-in commands are frequently used commands that are "built-into" the CP/M operating system. They are present whenever the CP/M operating system is loaded into memory. Built-in commands perform elemental functions, such as displaying a directory or erasing a file.

Apple SoftCard III CP/M has seven built-in commands. They are:

DIR	Displays a directory of files on diskette.
ERA	Erases a file or files.
REN	Renames a file.
SAVE	Saves the contents of memory in a file on diskette.
TYPE	Displays the contents of a file on the monitor screen.
USER	Creates another area within the same directory.
<d:>	Logs into another disk drive.

The following information is only an introduction to the built-in CP/M commands. For complete information about built-in CP/M commands, see the *Osborne CP/M User Guide* or the *CP/M Reference Manual*.



## DIR

The DIR command displays the names of the files (a directory) on a diskette. The general format of the command is

```
DIR [d:][filename.ext]
```

where [d:][filename.ext] is the optional file specification. Wild card file specifications can also be used. If a file specification is included with the DIR command, only those files with names that match the file specification will be displayed.

For example, to display the directory of all files on the currently logged drive, type

```
DIR
```

and press <RETURN>. To display the directory of a diskette in another drive, include the drive name as in the following example.

```
DIR B:
```

This displays the directory of the diskette in drive B:.

Here are some examples of how DIR is used.

DIR MBASIC.COM	Displays MBASIC.COM if the file exists on the currently logged diskette.
DIR A:*.COM	Displays all files with an extension of .COM on drive A:.
DIR B:	Displays all files on drive B:.
DIR A:A*.*	Displays all files on drive A: with names beginning with the letter A.

If there are no files on the diskette, or if no files match the file specification, CP/M responds with the message:

```
NO FILE
```

Complete information about the DIR command can be found in Chapter 1 of the *CP/M Reference Manual* or Chapter 4 of the *Osborne CP/M User Guide*.

## ERA

The ERA command erases specified files from a diskette. The general format of the command is

```
ERA [d:]<filename.ext>
```

where [d:]<filename.ext> is the file specification. You must always include a file specification with this command. Wild card specifications can also be used.

Here are a few examples of how ERA is used.

ERA B:TEMP.OLD	Erases the file TEMP.OLD on drive B:.
ERA C:*.BAS	Erases all files with the extension .BAS on drive C:.
ERA *.*	Erases all files on the diskette in the currently logged drive. If you attempt to erase all the files on a diskette, CP/M will ask:

```
ALL (Y/N)?
```

If you don't want to delete all the files on the diskette, type <N>.

Complete information about the ERA command can be found in Chapter 1 of the *CP/M Reference Manual* or Chapter 4 of the *Osborne CP/M User Guide*.

## REN

The REN command renames files. The general format of the command is

```
REN [d:]<new name>=<old name>
```

where <new name> and <old name> are file specifications. The first file specification can be preceded with a disk drive identifier. You cannot use wild card file specifications with the REN command.

The following are examples of how to use the REN command.

```
REN TEMP.NEW=TEMP.OLD    Rename TEMP.OLD as
                           TEMP.NEW.

REN B:PEAR.COM=APPLE.COM  Rename APPLE.COM on
                           drive B: as PEAR.COM.
```

Complete information about the REN command can be found in Chapter 1 of the *CP/M Reference Manual* or Chapter 4 of the *Osborne CP/M User Guide*.

## SAVE

The SAVE command saves the contents of memory in a specified disk file. A file specification must be included, but wild card file specifications are not allowed. If you run "off-the-shelf" application programs, you will rarely use this command. However, if you are engaged in assembly language programming, SAVE is very useful. More information on how to use SAVE can be found in Chapter 4 of the *Osborne CP/M User Guide* or Chapter 1 of the *CP/M Reference Manual*.

The format of the SAVE command is

```
SAVE <nnn> [d:]<filename.ext>
```

where [d:]<filename.ext> is the file specification. The <nnn>

argument is the number of *pages* to be saved. (A page of memory is equal to 256 bytes.)

To use the SAVE command, you must know how many memory pages are to be saved. The memory pages saved start at memory location 100 (hexadecimal). However, the <nnn> argument must be entered as a decimal number. See the "SAVE" section in the *Osborne CP/M User Guide* for instructions on how to convert the hexadecimal address to a decimal number.

The following example saves 26 pages of memory in a file called MYPROG.COM on disk drive C:.

```
SAVE 26 C:MYPROG.COM
```

## TYPE

The TYPE command displays the contents of a specified text file on the screen. The general format of the command is

```
TYPE [d:]<filename.ext>
```

where [d:] and <filename.ext> are file specifications. The <filename.ext> must be included, but wild card file specifications are not allowed.

For example, to display the contents of the file DUMP.ASM on the screen, type

```
TYPE DUMP.ASM
```

and press <RETURN>. If you attempt to TYPE a file that is not a text file, only meaningless characters will appear with unpredictable results.



DUMP.ASM is the only text file on the SoftCard III Master diskette.

Complete information about the TYPE command can be found in Chapter 1 of the *CP/M Reference Manual* or Chapter 4 of the *Osborne CP/M User Guide*.

## USER

The USER command segments disk memory into user areas. This command is useful for creating multiple file directories (one per user area) on disk. USER is of limited value with diskettes because of the small memory areas they contain. However, with a hard disk like ProFile, USER allows several users to maintain separate memory areas on the same disk.

The format of the USER command is

```
USER <n>
```

where <n> is any number between 0 and 15. If the specified number hasn't been used on that particular diskette or disk, USER creates the user area for that number. For example, if you already have three user areas (0, 1, 2) and you wish to create a fourth one, type

```
USER 3
```

and press <RETURN>. This immediately creates user area 3 and transfers you to that area. To go to another user area, type

```
USER <n>
```

where <n> represents the user area you want to access. Press <RETURN>. You are now in the desired user area.



If you attempt to execute a program contained in a COM type file which does not exist in the current user area, CP/M automatically searches user area 0 for that file. This applies to COM type files only.

Complete information about the USER command can be found in Chapter 1 of the *CP/M Reference Manual* or Chapter 4 of the *Osborne CP/M User Guide*.

## <d:>

The <d:> command changes the currently logged drive in multiple drive systems. The currently logged drive is the disk drive that you are currently working from. (See "CP/M File Naming Conventions" in this chapter.)

To change the currently logged drive, type the letter which represents the drive you wish to designate followed by a colon and press <RETURN>. For example,

```
B:
```

followed by <RETURN> changes the currently logged drive to drive B:. If you change the currently logged drive, CP/M changes the prompt letter accordingly. The <d:> command is discussed in Chapter 1 of the *CP/M Reference Manual* and in Chapter 4 of the *Osborne CP/M User Guide*.

## CP/M Transient Programs

CP/M transient programs (also called transient commands) reside on diskette (or disk) and are loaded into memory only when called and executed. Hence the name, "transient." Any file with the .COM extension can be considered a transient program. The .COM extension allows programs to be run by simply typing their filename followed by a <RETURN>. The Apple SoftCard III utility programs are actually transient programs, because of their .COM extensions.

Apple SoftCard III CP/M includes nine CP/M transient programs. They are:

ASM	Assembles 8080 assembly language programs.
DDT	Debugs 8080 assembly language programs.

DUMP	Displays a file in hexadecimal form.
ED	Creates and edits CP/M text files.
LOAD	Converts a HEX file into a COM file.
PIP	Transfers, copies, and/or appends disk files and devices.
STAT	Displays status information.
SUBMIT	Batch processes commands from a disk file.
XSUB	Allows character input to a program from a Submit file.

Transient programs are more complex than built-in commands. They perform many different tasks. Consequently, the mechanics of how transient programs work will not be discussed. Only the purpose of each transient program will be given. (Transient commands are described in detail in both the *Osborne CP/M User Guide* and the *CP/M Reference Manual*.)

## ASM

ASM is the CP/M 8080 assembler. It is used mainly for assembly language program development.

An assembler converts a source program written in assembly language into a HEX file. (A HEX file is the intermediate step in preparation of an assembly language program for execution.) The last step is performed with the LOAD transient program. LOAD converts the HEX file into an object file and loads it into memory. The object file is a file that contains the binary code the computer uses for program execution.

A description of ASM and instructions on how to use it are given in Chapter 4 of the *CP/M Reference Manual* and in Chapter 7 of the *Osborne CP/M User Guide*.

## DDT

DDT is the CP/M Dynamic Debugging Tool. It is used in conjunction with the ASM assembler to test and *debug* (find and correct problems in) assembly programs. DDT is also used for updating your programs and in installing special driver routines.

A description of DDT and instructions on how to use it are given in Chapter 5 of the *CP/M Reference Manual* and in Chapter 8 of the *Osborne CP/M User Guide*.

## DUMP

DUMP displays the contents of a disk file on the screen in hexadecimal form. DUMP is very useful for program development and in assembly language programming, in particular. More information on DUMP can be found in Chapter 2 of the *CP/M Reference Manual* and in Chapter 5 of the *Osborne CP/M User Guide*.



DUMP.ASM is the source listing of the DUMP program. It is listed in Chapter 2 of the *CP/M Reference Manual* as an example of an 8080 assembly language program written for the CP/M environment.

## ED

ED is the CP/M editor. It is used to create and edit CP/M ASCII (text) files. ED provides the basic requirements for inserting and deleting text, moving from line to line, and searching for text. However, if you plan to do a significant amount of text editing, you should obtain a more powerful editor or a *word processor* software package. (A word processor is a program that includes an editor and software for printer output and other features.)

For more information about ED and instructions on its use, see Chapter 3 of the *CP/M Reference Manual* and Chapter 6 of the *Osborne CP/M User's Guide*.

## LOAD

LOAD is another command that is useful in program development. It performs the last step in preparing an assembly language program for execution by converting a disk file of the extension .HEX into a machine-executable command file (with the extension .COM). See Chapter 2 of the *CP/M Reference Manual* and Chapter 5 of the *Osborne CP/M User Guide* for more information on the LOAD command.

## PIP (Peripheral Interchange Program)

PIP is one of the most frequently used CP/M programs. It is used for both running "off-the-shelf" application programs and program development.

PIP is also *extensible*. That is, it can perform various additional functions when arguments and parameters are added to its command line. By adding arguments, you can transfer files from one diskette to another, copy and append disk files, and transfer files to the console and printers.

Instructions on using PIP are given in Chapter 5 of the *Osborne CP/M User Guide* and in Chapter 1 of the *CP/M Reference Manual*.



Apple SoftCard III CP/M physical and logical device names differ slightly from those in other versions of CP/M. Because of this, PIP can only access the following physical devices:

CO1:	CO2:	CO4:
PR2:	PR3:	PR4:
PU2:	PU3:	PU4:
LS3:	LS4:	

## STAT

STAT is another transient program that performs a variety of functions. Depending on the arguments you include in the STAT command line, STAT provides general status information about

disk capacity, file sizes, file indicators, and device assignments. File indicators and device assignments can also be changed with STAT.



STAT indicates disk space for files in 1K byte units for floppy disk drives and in 4K byte units for the ProFile disk drive.

Instructions on using STAT are given in Chapter 5 of the *Osborne CP/M User Guide* and in Chapter 1 of the *CP/M Reference Manual*.



Before using STAT, see "CONFIG" in Chapter 4. Apple SoftCard III physical and logical device names differ slightly from those in other versions of CP/M.

## SUBMIT

SUBMIT is a transient program that allows CP/M commands to be executed from a disk file rather than from the keyboard. This allows for automatic processing and the creation of *turnkey programs*. (A turnkey program is a program that runs automatically when it is loaded into the system.)

SUBMIT is also used in program development for linking programs or sections of programs together for execution. For more information on SUBMIT, see Chapter 1 of the *CP/M Reference Manual* and Chapter 5 of the *Osborne CP/M User Guide*.

## XSUB

XSUB is actually a subset of SUBMIT. XSUB, when used with SUBMIT, allows character input from a disk file at all times during execution of programs. XSUB is most frequently used in program development for user input automation.

Instructions on using XSUB are given in Chapter 5 of the *Osborne CP/M User Guide* and in Chapter 1 of the *CP/M Reference Manual*.

## ***CP/M Error Messages***

Error messages tell you that an error condition has been detected by the operating system. There are four possible CP/M error messages. Each is described in the following sections along with a list of possible causes, in order of their likelihood of occurrence.

In each of the error message descriptions, X represents a disk drive identifier (A-D).



For descriptions of error conditions in the ASM, DDT, and ED transient programs, see the *Osborne CP/M User Guide* and the *CP/M Reference Manual*.

### ***BDOS ERR ON X: BAD SECTOR***

The BAD SECTOR error has a variety of causes; it does not necessarily mean that there is a bad sector on your disk or diskette. The possible causes are:

1. There is no diskette in the accessed drive.
2. The drive door is not closed.
3. The diskette was inserted into the specified drive improperly.
4. An attempt was made to access a drive not configured by the System Configuration Program (see SELECT error).
5. The diskette is bad or damaged.

When you receive a BAD SECTOR error message, CP/M waits for you to type a character. If you type CONTROL-C, a warm start is performed and you are returned to CP/M command level. Then type <R> to retry the read or write operation and continue execution. Typing any other character will cause the error to be ignored and execution to resume.

### ***BDOS ERR ON X: R/O***

The R/O error message usually means one of two things:

1. You have changed the diskette in a drive without typing CONTROL-C.
2. There is a write-protect tab covering the notch in your diskette.

Again, CP/M waits for you to type a character in response to this error message (see BAD SECTOR error). After you do so, a warm start is performed and you will be returned to CP/M command level.

### ***BDOS ERR ON X: FILE R/O***

The file R/O error message indicates a write was attempted to a file that has been marked "Read Only" with the STAT program.

When you receive this error message, CP/M waits for you to type a character at the keyboard. Type any character to perform a warm start and return to CP/M command level.

### ***BDOS ERR ON X: SELECT***

The SELECT error message indicates an attempt was made to access a nonassigned disk drive. (The device driver for the disk drive is not assigned.)

When you receive this error message, CP/M waits for you to enter a character. Type any character to perform a CP/M warm start and return to CP/M command level.

## *Apple SoftCard III Utility Programs*

48	Introduction
50	BOOT
51	CAT
52	CONFIG
60	COPY
71	MFT
73	PATCH
74	SOSXFER
78	TIME
79	TURNKEY

# 4

## Apple SoftCard III Utility Programs

### Introduction

In addition to the CP/M transient programs, the Apple SoftCard III package provides several useful utility programs. Utility programs, as the name implies, perform utility functions that help you maintain your software. The Apple SoftCard III utility programs are provided on the Apple SoftCard III Master diskette.



You may use the line editing commands described in Chapter 3 to edit utility program commands. CONTROL-C may be used to cancel commands or to exit the utility program.

The utilities provided are:

BOOT	Exits CP/M and reboots your Apple III system.
CAT	Displays an alphabetical listing of the directory on the specified drive.
CONFIG	Assigns physical SOS device drivers to logical CP/M devices.
COPY	Performs two functions: copies the contents of one diskette to another and creates CP/M system and data diskettes. (The two functions are described in separate sections.)
MFT	Transfers files from one diskette to another on a single disk drive system.

PATCH	Allows you to make program updates and modifications.
SOSXFER	Transfers SOS data files to CP/M diskettes.
TIME	Sets and reads the Apple III internal clock (if installed).
TURNKEY	Automatically executes a specified CP/M command line when a cold start is performed.

The Apple SoftCard III utility programs are described in the following sections.

Apple SoftCard III utility programs are run differently than SOS utility programs. With the exception of the CONFIG program, there are no *screen menus* (as in the SOS System Configuration Program). Apple SoftCard III utility programs are invoked at either CP/M *command level* or at the individual *program level*.

The Apple SoftCard III utility programs BOOT, CAT, TIME, and TURNKEY are executed from CP/M command level. To execute utility programs at command level, you simply type the program name and the arguments (if any). The CONFIG program, on the other hand, can only be run at the program level. This means that you must type the program name and press <RETURN> and wait for the program prompt to be displayed. (There is an exception where you run CONFIG at the command level. This is described in the CONFIG section of this chapter.)

The Apple SoftCard III utility programs COPY, MFT, and SOSXFER can be run from either the CP/M command level or the program level. For example, you may run MFT by typing

```
MFT<RETURN>
```

and wait for the program level prompt (an asterisk) to appear before adding the command line arguments. Typing CONTROL-C stops utility program execution and returns you back to CP/M command level.



The other method is to run MFT at CP/M command level. Arguments are added to the command line as in the following example.

```
MFT MBASIC.COM,DUMP.ASM
```

Both command line formats produce the same results. If a utility program is executed at CP/M command level, it automatically returns to the command level after execution.

Where applicable, both command line formats are described.

## BOOT

The BOOT utility program lets you reboot from CP/M command level. It performs the same function as a CP/M "cold start." When BOOT is executed, the CP/M operating system is reloaded and all programs that were in memory are erased.

To use BOOT, simply type:

```
BOOT
```

The system responds with the message:

```
Insert disk and press RETURN to reboot system:
```

Follow the instructions given in the prompt. CP/M is rebooted when the banner appears:

```
Apple SoftCard /// CP/M
56K Version 2.20
(C) 1982 Microsoft Corp.
```

BOOT may also be used to boot SOS, Apple III Pascal, Apple Business BASIC, Apple ][ emulation mode, or any Apple III application software.

## CAT

The CAT utility program displays an alphabetical list of CP/M files (a directory for a specified disk drive). It also lists the size of each file and the amount of unused space (in kilobytes) on the diskette. If you include a file specification in the command, the name of the file, its size, and the amount of unused space (in kilobytes) are also displayed.

The format of the CAT command is

```
CAT [d:][filename.ext]
```

where [d:] is the disk drive identifier and [filename.ext] is the name of a file. CAT \*.\* and other CP/M wild card file specifications can also be used.

Examples:

CAT B:	Displays the names of all the files on drive B:.
CAT *.<extension>	Displays the names of all the files with a specified extension on the default drive.
CAT *.BAS	Displays the names of all the .BAS (BASIC) files on the default drive.
CAT MBASIC.COM	Displays the file MBASIC.COM along with the size of the file and number of free bytes on the disk or diskette.

If the specified files are not found, CAT will return the message:

```
No file(s) found, xxxk bytes available
```



When CAT is used with drives other than Apple Disk III drives, such as ProFile, the displayed file size will differ from that displayed by the CP/M STAT command. CAT displays the actual size of the file, while STAT displays the amount of space on the disk or diskette allocated by the file. This figure may be larger.

## CONFIG

The CONFIG utility program ensures proper communication between CP/M and outside I/O devices. In particular, CONFIG:

1. Assigns SOS device drivers to CP/M physical devices. The assignments take effect only after a cold start.
2. Makes temporary SOS driver assignments which take effect immediately.
3. Changes CP/M logical and physical device assignments.

All three operations are described in the following paragraphs.

In "I/O Configuration," Chapter 2, we described how SoftCard III CP/M communicates with SOS character devices and block devices through SOS device drivers and CP/M logical and physical devices. The specific device drivers required for CP/M I/O communication are contained in the DRIVER.SOS file. These SOS device drivers are read into memory whenever a CP/M cold start is performed.

A cold start erases all previous memory contents and loads and initializes the CP/M operating system. Cold starts are performed under the conditions described in "CP/M Warm Start and Cold Start" in Chapter 3.

If any SOS device drivers are changed, the DRIVER.SOS file must reflect those changes. Changing the DRIVER.SOS file is an easy, two-step process which uses the SOSXFER and CONFIG utility programs. First you must copy the SOS.DRIVER file (from the SOS System Utilities diskette) into the DRIVER.SOS file (on a CP/M system boot diskette). Then, reboot CP/M with a cold start. At this time, CONFIG loads the new set of SOS device drivers into memory. In addition, CONFIG also matches the SOS device drivers to the appropriate CP/M physical device drivers as shown in Figure 5.

### Apple SoftCard III Device Configuration Program—Copyright (C) 1982 Microsoft

```

SOS Character Devices:          SOS Block Devices:

.SILENTYPE                      .D1
.PRINTER                        .D2
.CONSOLE                        .D3
.NULL                           .D4

Character Set: STANDARD         Keyboard: SHOLES

                                Current CP/M Device Assignments:

CON: = CO1:                    RDR: = RD1:                    PUN: = PU1:                    LST: = LS1:

CO1: = .CONSOLE                RD1: = .CONSOLE                PU1: = .CONSOLE                LS1: = .PRINTER
CO2: = .CONSOLE                RD2: = .CONSOLE                PU2: = .CONSOLE                LS2: = .SILENTYPE
CO3: = .CONSOLE                RD3: = .CONSOLE                PU3: = .CONSOLE                LS3: = .PRINTER
CO4: = .CONSOLE                RD4: = .CONSOLE                PU4: = .CONSOLE                LS4: = .SILENTYPE

A: = .D1                        B: = .D2                        C: = .D3                        D: = .D4

Command:

```

**Figure 5. CONFIG Screen Display (Default Drivers and CP/M Device Assignments)**

Figure 5 also shows the default display that appears when CONFIG is first invoked. It lists the default SOS device drivers and the CP/M device assignments. In the upper half of the display, the SOS device drivers that are active with CP/M are displayed. SOS Character Devices are devices for I/O communication, such as with the console. Block Devices, such as disk drives, are used for information storage.



The NULL character device is a "dummy" character device created for CP/M. It is used as the default assignment for CP/M if no other character device is assigned. Read operations to the NULL device produce a CONTROL-Z function. Write operations to NULL produce a "No Operations" function in CP/M. The NULL character device is not included in the DRIVER.SOS file.

In the lower half of the display, the CP/M device assignments are listed:

CON: = CO1: RDR: = RD1: PUN: = PU1: LST: = LS1:

They show the default CP/M logical-to-physical device assignments. (See the next paragraph for a discussion of logical and physical devices.) The next four lines show the CP/M physical device to SOS device driver assignments. The next to last line shows the CP/M disk drives assigned to the SOS block devices.

In Apple SoftCard III CP/M, there are four logical devices that can be directly accessed from CP/M:

CON: The system console device. All keyboard and screen I/O communication occurs through this device.

PUN: Auxiliary output device. An output only device that may be used for modems, PROM programmers, etc.

RDR: Auxiliary input device. An input only device that can be used in conjunction with PUN:.

LST: The system printer device. All printer output is sent to this device.

Each of the four logical devices can be assigned to one of four CP/M physical devices, as shown in the following list.

CON:	PUN:	RDR:	LST:
CO1:	PU1:	RD1:	LS1:
CO2:	PU2:	RD2:	LS2:
CO3:	PU3:	RD3:	LS3:
CO4:	PU4:	RD4:	LS4:



Apple SoftCard III CP/M physical device names differ from those in other CP/M versions. In addition, there are fewer device types available in Apple SoftCard III CP/M. These changes ensure compatibility with SOS.

Each of the CP/M physical devices can be assigned to a SOS character device driver. For example, the CP/M physical device CO1: is assigned to the SOS .CONSOLE device.

The CP/M physical devices CO1: and CO2: are treated differently than CO3: and CO4:.. When logical device CON: is assigned to either CO1: or CO2:., the character output to the console is *buffered*. That is, the actual output of characters is delayed, until keyboard input is requested (when a control character is sent or when disk I/O operations occur). When keyboard input has been requested, the delayed characters are sent to the console all at once. Buffering significantly increases the speed and performance of character output to the screen. However, buffering causes occasional problems.

For example, a program may send a message to the monitor screen and then perform a lengthy internal process. If the screen message was not terminated with a carriage return and the internal process does not include input from the keyboard, the message will not be displayed when it should be.

CP/M physical devices CO3: and CO4: do not buffer character output. To avoid the buffering problem, these devices could be assigned to the CON: logical device. However, the character output speed is significantly slower.

Device assignments are made through the CONFIG program or the STAT program. To execute either program a CP/M system boot diskette must be in drive A:.. The STAT program performs CP/M logical-to-physical device assignments only. The CONFIG program makes both CP/M logical-to-physical device assignments and SOS device driver to CP/M physical device assignments. This section shows you how to perform:

- CP/M physical device to SOS device driver assignments.
- CP/M logical to physical device assignments.
- Disk drive assignments.

To make device assignments, load the CONFIG program and follow the instructions for the procedure you wish to perform.



The following paragraphs assume the current SOS device drivers have been loaded into the DRIVER.SOS file with the SOSXFER program. If you are unsure of which device drivers you want to load, read the "I/O Configuration" section of Chapter 2, and Chapter 3 of the *Apple III Owner's Guide*.

### Running the CONFIG Program

Insert a copy of the Apple SoftCard III Master diskette into the built-in disk drive (drive A:) and load CP/M. Once the CP/M A> prompt appears, type

```
CONFIG
```

followed by a <RETURN>. The CONFIG program display will appear on the screen. All entries are made on the command line at the bottom of the display. If you make a mistake, use the backspace key (←) to correct it. To exit the CONFIG program, type <END>. (You may also abort the CONFIG program, by typing CONTROL-C.)

### Changing CP/M Physical Device to SOS Device Driver Assignments

CP/M physical device to SOS device driver assignments are entered in the following manner:

```
<CP/M physical device>=<SOS device driver>
```

For example, if you wanted to assign the SOS.PRINTER device driver to CP/M physical device LS2:, type

```
LS2:=.PRINTER
```

and press <RETURN>. The CONFIG display is updated to reflect the new assignment.

### Changing CP/M Logical to Physical Device Assignments

Changing the CP/M logical device to physical device assignment is performed in the following manner:

```
<logical device>=<physical device>
```

For example, if you want to change printers, type

```
LST:=LS2:
```

and press <RETURN>. Again, the CONFIG display is automatically updated to reflect the new assignment.

CP/M logical-to-physical device assignments may also be made at CP/M command level by typing:

```
CONFIG <CP/M logical device>=<SOS device driver>
```

This is a quick method for changing device assignments. The CONFIG program automatically makes the logical device to physical device assignment. Note that this is only a temporary assignment, but it takes effect immediately.

If, for example, you want to change printers and don't know the CP/M physical device names, type

```
CONFIG LST:=.SILENTYPE
```

and press <RETURN>. Like other Apple SoftCard III utility programs, CONFIG returns to CP/M command level after execution. The CONFIG display is not shown.

Logical-to-physical device assignments can also be made at CP/M command level with the STAT transient program. However, you must use CP/M physical device names in the STAT command line.

For example, to assign the same printer (Silentype) to the LST: logical device, type:

```
STAT LST:=LS1:
```

The difference between using STAT and CONFIG at CP/M command level is that you must remember which SOS device drivers are assigned to which CP/M physical devices. As with the CONFIG program, any device assignments you make at CP/M command level are not permanent. (The device assignments revert to default assignments in the DRIVER.SOS file.)

### Changing Disk Drive Assignments

You can also change the order of disk drives with the CONFIG program. A total of four disk drives can be used with CP/M. These are denoted by SOS device drivers .D1 through .D4. If you add a ProFile hard disk drive to your system, you can have two floppy disk drives and a ProFile segmented into two drives (.CPM1 and .CPM2). This is only the recommended configuration; you can use any combination of disk drives as long as the total remains four.



For more information on adding a ProFile disk drive to your system, see Chapter 5.

Disk drive assignments may be changed by typing in the arguments in the following format:

```
<CP/M disk drive identifier>=<SOS block device driver>
```

For example, if you want to reassign drive 3 as CP/M drive A:, type

```
A:=.D3
```

and press <RETURN>. The CONFIG display is updated to reflect the new assignment. After you have made a change in disk drive assignments, change the labels on the front of the disk drives (see "Apple SoftCard III Installation Procedure" in Chapter 2).

You may delete a disk drive assignment altogether by typing

```
NO <disk drive identifier>
```

at the command line, followed by a <RETURN>. For example, if you only have a two drive system and you wish to delete the third disk drive identifier, type

```
NO C:
```

followed by a <RETURN>. You may add the additional disk drive at any time by following the instructions in the previous step.

Once all the desired assignments have been made, type <END> or CONTROL-C to exit the CONFIG program. The computer responds with:

```
Make changes permanent (Y/N)?
```

Press <Y> if the assignment information is correct. (Make sure that there is no write-protect tab on the diskette.) The computer responds by writing the assignment information onto the CP/M diskette and returns to CP/M command level. If you have made an error, press <N> to cancel the CONFIG session and begin again.



Device assignments do not take effect until a cold start is performed.

### CONFIG Error Messages

If the CONFIG process is not successful, the screen will display one of five error messages.

Command Error	The command is not understood. Retype the command line and ensure it is in the correct format.
File Not Found	The DRIVER.SOS file does not exist.

	Check your directory and/or create a new driver file with the SOSXFER program.
Invalid CP/M Device	CP/M does not recognize the name you typed. Ensure the device name is a valid CP/M name and is entered correctly.
Invalid Drive	The drive you specified in the command line does not exist or cannot be deleted.
SOS Device Name Not Available	CP/M does not recognize the SOS device name.

## COPY

The COPY utility program performs two functions:

1. It copies the contents of a source diskette onto a destination diskette.
2. It creates CP/M system and data diskettes.

Both functions are described in the following sections.

### *COPY: Copying Diskettes*

The COPY utility program, when used with the equality (=) operator, copies the contents of a source diskette onto a destination diskette. COPY works with both floppy disk drive systems and "hard" disk drive systems such as ProFile.

When you use COPY to copy information onto a diskette or disk, the original information is erased from the diskette or disk. COPY automatically formats a diskette or disk if it hasn't already been formatted.



You cannot use COPY to copy files from a floppy disk drive to ProFile or from ProFile to floppy disk drives. The destination and source drives must be the same type and size. Use the PIP transient program to copy CP/M files between different drive types.

You can use the COPY command either from CP/M command level or from the COPY program level. From CP/M command level, the format is

```
COPY <d:>=<s:>[/F][/V]
```

where <d:> is the *destination drive* (the drive you wish to copy to, A: through D:). The <s:> argument is the *source drive* (the drive you are copying from, A: through D:). The [/F] and [/V] are software switches that enable either one or both options you may use with COPY.

The = operator and the <s:> argument indicate to the COPY program that a copy operation is to be performed. If the = operator and the <s:> argument are excluded, COPY will return the error message:

Command Error

The /F switch is the "format before copy" option. It instructs the COPY program to format the destination diskette before the actual copying of files takes place. This is performed even if the disk is already formatted.

The /V switch is the "verify copy" option. It instructs COPY to reread the copied data on the destination drive and compare it with the original data on the source drive. This verifies that no errors occurred during the copying process.

Examples:

COPY B:=A:/V      Copies the contents of drive A: onto drive B: and verifies.

COPY A:=C:/V/F    Formats the diskette or disk in drive A: and then copies the contents of drive C: onto drive A:. The verify option is performed last.

When COPY is run, the program prompts you as to when to insert diskettes into the appropriate drive. See "Backing Up The Apple SoftCard III Master Diskette" in Chapter 2 for examples of screen prompts and messages.

You may also run COPY from the program level by typing

COPY

and pressing <RETURN>. The computer loads the COPY program and displays the COPY program banner:

```
Apple SoftCard /// CP/M
Disk Backup Program
(C) 1982 Microsoft Corp.
```

\*

When you see the program level prompt (\*) type in the appropriate arguments in the following format:

```
<d:>=<s:>[/F][/V]
```

The <d:>, <s:>, [/F], and [/V] arguments are identical to those described in the command level format discussion.

Examples:

C:=A:            Copies the contents of drive A: onto drive C:

B:=C:/V         Copies the contents of drive C: onto drive B: and verifies.



You may use COPY with either a single drive system or multiple drive system. With a single drive system, you must specify <destination drive> and <source drive> as the same drive.

### *COPY Error Messages*

If the copy process is not successful, the screen will display one of three error messages.

Disk Write Protected	There is a write-protect tab on the diskette you want to format. Remove the write-protect tab and format the diskette (use the /F option).
Disk I/O Error	The computer is unable to format the diskette for some reason. Ensure you have a diskette in the disk drive and that the disk drive door is closed.
Command Error	The command is not understood. Retype the command line and ensure it is in the correct format.

### *COPY: Creating CP/M System and Data Diskettes*

The COPY utility program can also create CP/M system and data diskettes when the appropriate option switches are added to the command line. COPY works with both floppy disk drive systems and "hard" disk drive systems such as ProFile.

You can use the COPY command either from CP/M command level or from COPY program level. From CP/M command level, the format is

```
COPY <d:>[/S][/D][/F][/V]
```

where <d:> is the destination drive name (A: through D:). The [/S], [/D], [/F] and [/V] arguments are software switches that enable different options you may use, as follows:

Switch	Option
/S	Create a system diskette
/D	Create a data diskette
/F	Format disk/diskette
/V	Verify contents



The [/S] or [/D] arguments must be included in the command line. However, they cannot be included together.

The /S switch instructs COPY to create CP/M system diskettes. COPY with the /S switch also formats the diskette if it hasn't been formatted previously. If the diskette is already formatted, the files on the diskette are not deleted unless the /F switch is used. If your system includes a ProFile, COPY with the /S switch must be used on the SOS .CPM1 and .CPM2 block devices to allow them to be assigned as drive A:. (See "Loading CP/M onto ProFile" in Chapter 5.)

The /D switch instructs COPY to create a data diskette. As with the /S switch, if the diskette is already formatted the files on the diskette are not deleted unless the /F switch is used. If the diskette is already a CP/M diskette, the CP/M system is removed, and an additional 12K bytes of disk space is made available for use by programs and data.

Data diskettes are not recommended for single drive systems. CP/M cannot perform a warm start when a data diskette is in drive A:. See "CP/M Diskettes" in Chapter 3 for more information.

The /F switch instructs COPY to format the diskettes. The /F switch may also be used with the /S and /D switches. This "forces" a formatting of the diskette and, as a consequence, deletes all files. When the /F switch is used with nonremovable block devices .CPM1 and .CPM2, the message

```
Warning - All CP/M Files will be erased
Continue (Y/N)?
```

appears. If you press <Y>, all CP/M files on the disk are deleted. Formatting does not affect any SOS files in other ProFile volumes. If you press <N>, the COPY operation is aborted.

The /V switch, when used with the /S switch, verifies that the newly created system disk or diskette is correct.



When adding a ProFile disk drive to your system, the Volume Configuration Utility program (on the SOS-CP/M Utilities diskette) automatically formats ProFile when it defines the device driver. For more information about ProFile, see Chapter 5 of this manual.

The following procedures show how to create CP/M system, system boot, and data diskettes. Use the procedure (for single drive systems or multiple drive systems) that is appropriate for your system.



CP/M system and boot diskettes that are created with the following procedures include only the CP/M operating system with the CP/M built-in commands. They do not include CP/M transient commands or CP/M utility programs. These programs (if desired) must be copied onto a CP/M system or boot diskette with the MFT utility program or PIP transient program. (The MFT utility program is described below in this chapter and the PIP transient program is described in the *Osborne CP/M User Guide*.)



## Creating CP/M System and System Boot Diskettes with a Single Drive System

1. Insert a backup copy of the SoftCard III Master diskette into the built-in drive (drive A:).

2. At CP/M command level, type

COPY A:/S

and press <RETURN>. The program displays:

```
Apple /// SoftCard CP/M
Disk Backup Program
(C) 1982 Microsoft Corp.
```

Insert CP/M SYSTEM disk & press RETURN

Leave the current diskette in drive A: and press <RETURN>. After a few seconds, the screen displays:

Insert DESTINATION disk & press RETURN

3. Insert the destination diskette (this can be either a blank diskette or any diskette that you want to overwrite) and press <RETURN>. When the copy process is complete, the screen displays:

Operation complete

Again (Y/N)?

This completes the copy process for CP/M system diskettes. If you wish to create more than one CP/M system diskette, type <Y> and repeat steps 1 through 3 of this procedure. If you have no more system diskettes to copy, type <N> to return to CP/M command level.

If you wish to create a CP/M system boot diskette, continue with steps 4 through 7.

4. When you see the message

```
Insert CP/M System disk into drive A:
Press RETURN
```

insert a copy of the Apple SoftCard III Master diskette into drive A: and press <RETURN>.

5. When you see the A> prompt, type:

MFT DRIVER.SOS

CP/M loads the single drive file transfer program and displays:

```
Apple SoftCard /// CP/M
Single Drive File Transfer Program
(C) 1980 by Mycroft Labs
```

\*

Insert SOURCE disk and press RETURN

6. Insert the appropriate diskette and press <RETURN> to start the copy process. The program displays:

```
Copying -
DRIVER.SOS
```

When the DRIVER.SOS file is read into memory, the screen displays:

Insert DESTINATION disk and press RETURN

7. Remove the Apple SoftCard III Master diskette copy and insert the CP/M boot diskette you want to copy the DRIVER.SOS file onto. Press <RETURN>.

When the copy process is complete, the screen displays:

Insert CP/M System disk and press RETURN

- If you wish to create more than one CP/M boot diskette, repeat this procedure. If you do not, insert either a copy of the Apple SoftCard III Master diskette or a CP/M boot diskette into drive A:. Your new CP/M boot diskette will now boot and can be used to store programs and data.



If you wish to verify that the DRIVER.SOS file was copied onto your boot diskette, insert the boot diskette into drive A: and type DIR followed by <RETURN>. The filename DRIVER.SOS should be displayed on the screen.

### *Creating CP/M System and System Boot Diskettes with a Multiple Drive System*

- Insert a backup copy of the Apple SoftCard III Master diskette into the built-in drive (drive A:).
- At CP/M command level, type

COPY B:/S

and press <RETURN>. The screen displays

```
Apple SoftCard /// CP/M
Disk Backup Program
(C) 1982 Microsoft Corp.
```

```
Insert CP/M SYSTEM disk into drive A:
Insert DESTINATION disk into drive B:
```

Press RETURN to begin

You should already have a copy of your Apple SoftCard III Master diskette in drive A:.

- Insert the diskette you want as a system diskette into drive B:. Press <RETURN> to start the copy process. The screen will display

Formatting...

to indicate that it is formatting the diskette. When the diskette is completely formatted, the screen displays:

Copying...

When the copy process is complete, the screen displays:

Operation complete

Again (Y/N)?

- This completes the copy process for CP/M system diskettes. If you wish to create more than one CP/M system diskette, type <Y> and repeat steps 1 through 3 of this procedure. If you do not, press <N> to return to CP/M command level.

If you wish to create a CP/M boot diskette, continue with step 5.

- When you see the A> prompt, type:

PIP B:DRIVER.SOS=DRIVER.SOS

and press <RETURN>. The PIP transient program copies the DRIVER.SOS file onto the CP/M system boot diskette. When you see the A> prompt again, you have a CP/M system boot diskette to store programs and data.

If you wish to create more than one CP/M system boot diskette in drive A:, insert another diskette into drive B: and repeat this procedure. If you do not, insert either a copy of the Apple SoftCard III Master diskette or a CP/M system or CP/M system boot diskette.



If you wish to verify that the DRIVER.SOS file was transferred, type DIR B: and press <RETURN>. This displays a directory of files on drive B:. At this time, you should have only the DRIVER.SOS file in drive B:'s directory.

### Creating CP/M Data Diskettes

1. Insert a copy of your Apple SoftCard III Master diskette into the built-in drive and type:

```
COPY B:/D
```

Press <RETURN>. The computer will display:

```
Apple SoftCard /// CP/M
Disk Backup Program
(C) 1982 Microsoft Corp.
```

```
Insert disk into drive B:
```

```
Press RETURN to begin
```

2. When the copy process is completed, the screen displays

```
Operation complete
```

```
Again (Y/N)?
```

3. If you wish to create more than one CP/M data diskette, press <Y> and repeat this procedure. If you do not, press <N>. Your new CP/M data diskette can now be used to store programs and data.

### MFT

The MFT utility program transfers files from one diskette to another on a single drive system. MFT may be used from either CP/M command level or from MFT program level.



Before using MFT, insert the Apple SoftCard III Master diskette into drive A:.

To use MFT from CP/M command level, type

```
MFT <file1> [,<file2>,<file3>...]
```

where <file> is a standard CP/M file specification consisting of a one to eight character filename followed by a one to three character filename extension. (See "CP/M File Naming Conventions" in Chapter 3 for an explanation of file specifications.)

To use MFT at the program level, type

```
MFT
```

and press <RETURN>. Once the MFT program is loaded into memory, the screen displays:

```
Apple SoftCard /// CP/M
Single Drive File Transfer Program
(C) 1980 by Mycroft Labs
```

```
*
```

Type the file specifications of the files to be transferred, in the following format:

```
<file1> [,<file2>,<file3>...]
```

The arguments (<file1>, <file2>, <file3>...) are identical to those executed at the command level.

From either level, MFT prompts you with:

Insert SOURCE disk and press RETURN

Insert the source diskette (the diskette you wish to copy from) into drive A: and press <RETURN>. During the copy process, the screen displays:

```
Copying -
<file1>
<file2>
```

After the source files are read into memory, the screen displays:

Insert DESTINATION disk and press RETURN

Insert your destination diskette into drive A: and press <RETURN>. When all files are copied onto the destination diskette, the screen displays:

Insert CP/M System disk and press RETURN

Insert a CP/M diskette (system, system boot, or Apple SoftCard III Master copy) into drive A:. Pressing the <RETURN> key completes the process and returns you to CP/M command level. If you wish to abort the transfer process, type a CONTROL-C.



Make sure you have a CP/M system or boot diskette in drive A: before executing a CONTROL-C.

Examples:

```
MFT *.*           Transfers all files on the
                   source diskette to the
                   destination diskette.

MFT DRIVER.SOS,CONFIG.COM
                   Transfers DRIVER.SOS
                   and CONFIG.COM. from
                   the source diskette to the
                   destination diskette.
```

## PATCH

PATCH is used only to install program updates and modifications. You will not need to use this utility program for normal operation of your CP/M system.

PATCH can run from CP/M command level or the program level. When executed at CP/M command level, PATCH always exits to CP/M command level when finished.



Do not use this utility unless you have experience with assembly language programming and are knowledgeable about the CP/M operating system.

To run PATCH at the program level, type

```
PATCH
```

followed by a <RETURN>. When the PATCH program is loaded, the PATCH program banner and program level prompt (\*) are displayed. You may enter arguments in the following format:

```
[d:][filename.ext] <offset>=[<p1> <p2> <p3>...]
[( <v1> <v2> <v3>)]
```

where [d:][filename.ext] is the file specification. The <offset> argument is a one-to-six digit hexadecimal byte offset. The <p1>, <p2> and <p3> arguments are two-digit hexadecimal patch bytes. The <v1>, <v2>, and <v3> arguments are optional two-digit hexadecimal verification bytes. Spaces are required between the byte arguments.

The bytes following the equality operator (=) are written to the file (if specified) or diskette at the specified offset (after the program has verified that the bytes enclosed in parentheses are at the specified location).

Once the patch is made, the asterisk prompt will reappear. Repeat the procedure to install another patch, or type CONTROL-C to return to CP/M command level.

If the PATCH process is not successful, the computer will display one of two error messages.

Command Error	The command is not understood. Retype the command line and ensure it is in the correct format.
Verification Error	This error results when the bytes at the given offset are not the same as the bytes enclosed in parentheses. No verification error will result if the patch has already been made.

Examples:

```
PATCH 1234=10 20 30 (12 23 45)
PATCH B: 1234=10 20 30 (12 23)
PATCH B:MBASIC.COM 1234=10 20 30 (12 23 34 45)
```

## SOSXFER

The SOSXFER utility program copies Apple III SOS files onto CP/M diskettes (system, system boot, or data). Although SOS files are not compatible with CP/M, you can use SOSXFER to transfer SOS ASCII and data files and the SOS.DRIVER file to your CP/M diskettes.

The SOSXFER utility program is contained on the Apple SoftCard III Master diskette. You can invoke SOSXFER from any disk drive.

SOSXFER may be executed from either CP/M command level or the SOSXFER program level. Arguments in both formats are identical.

Invoke SOSXFER from CP/M command level by typing

```
SOSXFER [d:]<CP/M filename.ext>=[d:]<SOS filename>
```

followed by a <RETURN>. The [d:] arguments specify the disk drives of both the destination and source files. The argument <CP/M filename.ext> is the name of the CP/M destination file. The argument <SOS filename> is the name of the SOS file you wish to copy.



For single drive systems, specify drive A: for both source and destination drives. After you press <RETURN>, the computer will prompt you to insert the appropriate diskette into the drive.

SOSXFER is invoked at program level by typing

```
SOSXFER
```

followed by a <RETURN>. SOSXFER is loaded into memory and the screen displays

```
Apple SoftCard /// CP/M
SOS to CP/M File Transfer Program
(C) 1982 Microsoft Corp.
```

\*

The SOSXFER command format is

```
[d:]<CP/M filename.ext>=[d:]<SOS filename>
```

followed by a <RETURN>. The command line arguments are identical to those in the CP/M command level format.

Once SOSXFER arguments have been entered, the screen displays:

```
Insert SOS disk into drive <d2:>
Insert CP/M disk into drive <d1:>
Press RETURN to begin
```

Follow the instructions given in the prompts. Insert the SOS source diskette and the CP/M destination diskette in the appropriate drives. After you press <RETURN>, the screen displays:

Working...

Transfer complete

If SOSXFER is invoked from CP/M command level, it automatically exits back to CP/M command level. If SOSXFER is invoked from program level, it returns to program level, as indicated by the SOSXFER asterisk prompt (\*).

### *SOSXFER Copy Procedures*

The following procedures may serve as examples for copying other SOS files onto CP/M diskettes. Separate procedures are provided for single and multiple drive systems.

#### *SOSXFER Single Drive Copy Procedure*

1. Insert a copy of the Apple SoftCard III Master diskette into drive A:.
2. Type

SOSXFER A:DRIVER.SOS=A:SOS.DRIVER

and press <RETURN>. The screen displays:

```
Apple SoftCard /// CP/M
SOS to CP/M File Transfer Program
(C) 1982 Microsoft Corp.
```

Insert SOS disk and press RETURN

3. Insert the (Apple III) System Utilities diskette into drive A: and press <RETURN>. The SOSXFER program copies the SOS.DRIVER file into memory. It then prompts you to:

Insert CP/M disk and press RETURN

4. Remove the System Utilities diskette from drive A: and insert the destination diskette (either a CP/M system diskette or a copy of the Apple SoftCard III Master diskette).
5. Press <RETURN>. Repeat steps 3 and 4 again, as instructed by the prompts on the screen.
6. When the CP/M command level prompt appears, the SOSXFER operation is complete.

#### *SOSXFER Multiple Drive Copy Procedure*

1. Insert a copy of the Apple SoftCard III Master diskette into drive A:.. Insert the (Apple III) System Utilities diskette into drive B:.
2. Type

SOSXFER A:DRIVER.SOS=B:SOS.DRIVER

and press <RETURN>. The screen displays:

```
Apple SoftCard /// CP/M
SOS to CP/M File Transfer Program
(C) 1982 Microsoft Corp.
```

```
Insert SOS disk into drive B:
Insert CP/M disk into drive A:
Press RETURN to begin
```

3. Insert the diskettes as instructed and press <RETURN>. During the copy process the screen displays:

Working...

When the copy process is complete, the screen displays:

Transfer complete

4. When the CP/M command level prompt appears, the SOSXFER operation is complete.

## SOSXFER Error Messages

If the copy process is not successful, the computer will display one of two error messages.

File not found	The file you specified in the command line does not exist. Check the spelling of the file name and re-enter the command line.
Command Error	The command is not understood. Retype the command line and ensure it is in the correct format.

## TIME

The TIME utility program sets and reads the Apple III internal clock (if installed).

You can set either time or date or both. To set both time and date, type

```
TIME [date]<hh>:<mm>:<ss>[AM][PM]
```

The date must be entered in the format: dd-mon-yy or dd/mm/yy. If both date and time are entered, the date must be specified first. The day of the week is set automatically by the Apple III clock.

Time can be set in either 24-hour format or 12-hour format. Once you have entered the desired time and date press <RETURN>. The screen displays:

Press RETURN to set the time

The TIME program waits until you press <RETURN> before restarting the Apple clock. This allows you to synchronize the Apple III clock with another clock or your watch.

To read the time and date, type TIME at CP/M command-level. The day, date, and time are displayed, as in the following example:

```
Wed 16-Jun-82 10:40:37 PM
```

If you want to display the date only, type:

```
TIME D
```

If you want to display the time only, type:

```
TIME T
```

Examples:

Set the date and the time:

```
TIME 10-Feb-82 11:40:00 AM
```

Set the date only:

```
TIME 10-4-82
```

Set the time only:

```
TIME 1:23:40 PM
```

## TURNKEY

The TURNKEY utility program lets you implement a *turnkey* system on your Apple III. A turnkey system automatically executes a program or command when the Apple III is booted with a *cold start*.

Once you have executed the TURNKEY program, any CP/M command line (that is, any CP/M program or command) can automatically be executed each time the system is booted. Thus, you can automatically load and run programs without ever seeing the CP/M A> prompt. To use the TURNKEY program, type

```
TURNKEY [command line]
```

where [command line] is any legal CP/M program or command. The command line used with TURNKEY must be stored on a CP/M

system or boot diskette in the currently logged drive. When you boot the system, the command line is executed immediately after CP/M is loaded.

To change the command line on a diskette, type TURNKEY again with a new command line. Typing TURNKEY without a command line will remove all command lines from the diskette.

Examples:

TURNKEY CAT	Displays the directory on the default drive when you boot the system.
TURNKEY MBASIC MAILLIST	MBASIC is automatically loaded after CP/M. The BASIC program MAILLIST is loaded and executed after MBASIC.

## Running CP/M with ProFile

- 82 Setting Up ProFile for CP/M
- 83 ProFile Space Allocation
- 84 CP/M ProFile Configuration Procedure
- 88 How to Use CP/M with ProFile
- 88 Loading CP/M onto ProFile
- 89 Changing the ProFile Drive Assignment
- 89 Expanding the CP/M Space on ProFile



## 5 Running CP/M with ProFile

The Apple SoftCard III CP/M system and the ProFile disk drive are a powerful combination for your Apple III. The ProFile disk drive increases Apple III disk memory capacity by 5 megabytes (5 million bytes).

CP/M has several provisions for using a fixed media disk drive (also known as a "hard disk drive") such as ProFile. This chapter discusses how to use CP/M with the ProFile disk drive.

### Setting Up ProFile for CP/M

Once ProFile is set for operation (see the *Apple III ProFile Owner's Manual* for instructions), set up the device drivers for ProFile and allocate disk space for CP/M with the procedures in the following sections.



The following procedures assume the ProFile Interface Card is installed in peripheral slot 4 of your Apple III. If not, the two block device driver files (.CPM1 and .PROFILE) on the SOS-CP/M Utilities diskette must be reconfigured for the current ProFile configuration. Use the System Configuration Program (SCP) on the System Utilities diskette to change the DRIVER.SOS and SOS.DRIVER files.

### **ProFile Space Allocation**

This section explains how to use the Volume Configuration Program. This program defines the drivers needed for using CP/M with the ProFile disk drive and the amount of disk space required.

For the CP/M operating system, we recommend you allocate 3200 blocks in two volumes. A *volume* refers to any form of mass-storage medium. Each volume should be allocated 1600 blocks. Use the first volume as your primary storage medium and the second volume for expansion.



There can be only two active volumes per ProFile.

### **Volume Configuration Program**

To allocate space on the ProFile disk drive for CP/M, proceed as follows:

#### *Space Allocation Procedure*



If you make a mistake, an error message appears in the upper half of the display. The error message gives instructions on what to do next.

1. Insert the SOS-CP/M Utilities diskette in drive A:.
2. Press <CONTROL-RESET> to boot the diskette.
3. When the Volume Configuration Program display appears, locate the message:

Pathname of new file? [.PROFILE/CPM1]

in the lower left corner of the screen.



If you press <RETURN> after each prompt, the default names and values are entered.

4. Type

.PROFILE/CPM1 <RETURN>

to create the first ProFile volume for CP/M.

- When the cursor moves to the next message line

Length of new file in blocks? [280 ]

(280 is the default value of the first volume), you can enter any number between 257 and 9700 to indicate the amount of disk space you wish to allocate. Type:

1600<RETURN>

This defines the memory size of the first CP/M block device and automatically formats that portion of the ProFile. If you don't define the size of the volume, a default size of the volume (280 blocks) is entered.

The program returns the message:

File PROFILE/CPM1 created with xxxx blocks.

- Once the first CP/M volume has been created, the program prompts you for the next file. Type

.PROFILE/CPM2

followed by a <RETURN>. This defines the second CP/M volume. The next prompt asks for the length of the new file (volume) in blocks. Type:

1600<RETURN>

This concludes the Space Allocation Procedure.

### ***CP/M ProFile Configuration Procedure***

The next stage of configuring CP/M for ProFile is to load the ProFile block device drivers into CP/M. Use the procedure that is appropriate to your system (single drive or multiple drive) for loading the ProFile drivers.

#### ***CP/M ProFile Configuration Procedure for Single Drive Systems***

The following procedure configures the ProFile for a CP/M single drive system (built-in drive only).

- After creating the second volume, remove the SOS-CP/M Utilities diskette from drive A:.
- Insert a copy of the Apple SoftCard III Master diskette into drive A:.
- Type <CONTROL-RESET> to boot the diskette.
- When the A> prompt appears, type:  
SOSXFER A:DRIVER.SOS=A:DRIVER.SOS
- Remove the Apple SoftCard III Master diskette and insert the SOS-CP/M Utilities diskette into drive A: . Press <RETURN>.
- The SOSXFER program copies a portion of the DRIVER.SOS file into memory. At this point, the SOSXFER program prompts you with the message:

Insert CP/M System disk into drive A:

If you wish, you can take this opportunity to update a copy of your Apple SoftCard III Master diskette or CP/M boot diskette. We recommend you use a copy of your Apple SoftCard III Master diskette to save the DRIVER.SOS file. Insert this diskette into drive A: and follow the instructions given in the prompts.

- When the copy process is complete, the screen displays:  
Transfer complete  
Insert CP/M System disk into drive A:  
Press RETURN
- Press <RETURN>. (The Apple SoftCard III Master diskette copy should still be in drive A:.) When you see the A> prompt, type:  
CONFIG  
CONFIG reads the DRIVER.SOS file and loads the new ProFile CP/M drivers.
- When the CONFIG display appears, the new CP/M block device drivers (.CPM1 and .CPM2) appear in the SOS Block Device column. These devices can be assigned to a CP/M disk drive identifier.

Assign the SOS block devices to the CP/M disk drive identifiers in the following format:

<CP/M disk drive identifier>=<SOS block device>

Examples:

C:=.CPM1<RETURN>

D:=.CPM2<RETURN>

10. When all assignments have been made, type <END> and press <RETURN>. The CONFIG program returns the message:
 

Make changes permanent (Y/N)?

Type <Y> to return to CP/M command level. Type <N> if you wish to abort the CONFIG program.
11. When you are at CP/M command level, type <BOOT> to reload and reinitialize CP/M. This loads the new device assignments into memory.

This completes the I/O configuration procedure for adding a ProFile to your CP/M system. Both ProFile CP/M volumes have been automatically formatted by the Volume Configuration Utility. Proceed to "How to Use CP/M with ProFile" for information on using ProFile with CP/M.

## *CP/M ProFile Configuration Procedure for Multiple Drive Systems*

The following procedure configures ProFile to a CP/M multiple drive system (with one or more external floppy disk drives).

1. After creating the second CP/M volume, remove the SOS-CP/M Utilities diskette from drive A: and insert it into drive B:.
2. Insert a copy of the Apple SoftCard III Master diskette into drive A:.
3. Type <CONTROL-RESET> to load the Apple SoftCard III Master diskette.

4. When the A> prompt appears, type:

SOSXFER A:DRIVER.SOS=B:SOS.DRIVER

5. Press <RETURN> and follow the instructions given by the prompts. When the SOSXFER program finishes copying the SOS.DRIVER file onto the CP/M boot diskette, the screen displays:

Transfer complete  
Insert CP/M System disk into drive A:  
Press RETURN

Insert the diskette into drive A: and press <RETURN> as instructed.

6. When you see the A> prompt, type:

CONFIG

CONFIG reads the DRIVER.SOS file and loads the new CP/M ProFile drivers.

7. When the CONFIG display appears, the new CP/M block device drivers (.CPM1 and .CPM2) appear in the SOS Block Device column. These devices may be assigned to a CP/M disk drive identifier.
8. Assign the SOS block devices to the CP/M disk drive identifiers in the following format:

<CP/M disk drive identifier>=<SOS block device>

Examples:

C:=.CPM1<RETURN>

D:=.CPM2<RETURN>

9. When all assignments have been made, type <END> and press <RETURN>. The CONFIG program returns the message:

Make changes permanent (Y/N)?

Type <Y> to return to CP/M command level. Or, if you want to abort the CONFIG program, type <N>.

- When you are at CP/M command level, type <BOOT> to reload and reinitialize CP/M. This loads the new device assignments into memory.

This completes the I/O configuration procedure for adding ProFile to your CP/M system. Both ProFile CP/M volumes have been automatically formatted by the Volume Configuration Utility. Proceed to "How to Use CP/M with ProFile" for information on using ProFile with CP/M.

## ***How to Use CP/M with ProFile***

---

This section provides general information on using ProFile with CP/M. We recommend loading the CP/M operating system onto ProFile and assigning it as the currently logged drive, as described in the following sections.

### ***Loading CP/M onto ProFile***

Load CP/M onto ProFile as follows:

- Insert a copy of the Apple SoftCard III Master diskette into drive A:.
- Type
 

```
COPY <d:>/S
```

 and press <RETURN>. The <d:> argument is the current disk drive identifier of ProFile.
 

During the copy process, the screen displays:

```
Copying....
```
- When the copy process is complete, the screen displays:
 

```
COPY complete
Again (Y/N)?
```
- Press <N> to return to CP/M command level.

This completes the ProFile copy procedure. You now have the CP/M operating system on ProFile. This allows you to use ProFile as a system disk. You may also want to transfer other CP/M files, such as the DRIVER.SOS file and transient programs, onto ProFile. CP/M files are transferred with the PIP transient program.

The next step is to make ProFile your default drive (drive A:).

### ***Changing the ProFile Drive Assignment***

CP/M warm starts are always performed from a CP/M system disk or diskette in drive A:. ProFile can be assigned as drive A: through the CONFIG utility program (see Chapter 4).

If ProFile is assigned as drive A:, it cannot be used for a CP/M cold start. A CP/M cold start always loads CP/M into memory from the "built-in" drive. Therefore, you must have a CP/M system boot diskette in the built-in drive for cold starts.

### ***Expanding the CP/M Space on ProFile***

To expand the amount of disk space allocated to ProFile CP/M volumes, proceed as follows:

- Save all CP/M files either in the .CPM2 volume or on diskette. Use the CP/M PIP transient program for transferring files.
- Reassign the built-in drive as the default drive with the CONFIG utility program.
- Insert the (Apple III) System Utilities diskette into the built-in drive and press <CONTROL-RESET>.
- Once the System Utilities diskette has been booted, follow the procedure given in the "Set Write Protection" section of Chapter 5 of the *Apple III Owner's Manual* to unlock and then delete block device .CPM1.



This procedure will erase all files on the .CPM1 volume.

5. Remove the System Utilities diskette from the built-in drive and insert the SOS-CP/M Utilities diskette.
6. Use the Volume Configuration Utility program to redefine block device .CPM1 and allocate the desired amount of disk space. (See "ProFile Space Allocation" in this chapter for instructions.)
7. Reboot the system to load the drivers into memory.
8. Use the procedure described in "Loading CP/M onto ProFile" to make ProFile a CP/M system disk.
9. Use the PIP transient program to transfer CP/M files back to ProFile.

This completes the procedure for expanding CP/M disk space on ProFile.

## Appendix A

### Apple SoftCard III Specifications

92	General Specifications
93	CP/M Operating System Specifications
93	Standard CP/M Transient Programs Provided
93	Apple SoftCard III Utility Programs Provided
94	CP/M Program Compatibility
94	Microsoft BASIC Interpreter Specifications

# Appendix A

## Apple SoftCard III Specifications

### General Specifications

---

Processor:	Z80A microprocessor (4 MHz)
Clock Rate:	Operates at an effective clock rate of 2.041 MHz. Synchronized and phase locked with the Apple III clocks.
Modes:	Z80 (active) and 6502 (also active, 1/5 speed—not accessible to user). Switch between the Z80 and 6502 modes with software commands.
Installation:	Apple SoftCard III may be installed in any of the Apple III I/O expansion slots. Slot 2 is recommended. Connection is made through a 50-pin edge-connector. No hardware or software modifications are needed.
Memory Mapping:	Offsets Z80 addresses so that CP/M programs, when loaded in the usual location, will not interfere with Apple screen memory functions.
Compatibility:	When the Apple III is not in Z80 mode, the Z80 microprocessor is inactive and the Apple III runs in 6502 mode, as usual. In Z80 mode, all standard SOS drivers are supported.

I/O Operations:	In Z80 mode, I/O continues to be handled by the 6502 microprocessor.
Power Consumption:	Average 400 milliamps at +5.0 volts (2.1 watts).
Size:	The physical dimensions are 4.25 in. (height) x 7.40 in. (length) x 0.12 in. (width).

### CP/M Operating System Specifications

---

Version:	CP/M 2.20 (56K) 51K maximum user program area
----------	---

### Standard CP/M Transient Programs Provided

ASM	Assembles 8080 assembly language programs.
DDT	Debugs 8080 assembly language programs.
DUMP	Displays a file in hexadecimal form.
ED	Creates and edits CP/M text files.
LOAD	Converts a HEX file into a COM file.
PIP	Transfers, copies, and/or appends disk files and devices.
STAT	Displays status information.
SUBMIT	Batch processes commands from a disk file.
XSUB	Allows character input to a program from a Submit file.

### Apple SoftCard III Utility Programs Provided

---

BOOT	Reboots the Apple III.
CAT	Displays diskette directory in alphabetical order and available disk space in kilobytes.
CONFIG	Assigns CP/M logical devices to Apple III physical devices, and SOS device drivers to CP/M physical devices.

COPY	Copies and formats diskettes and creates CP/M system and data diskettes.
MFT	Transfers files from one diskette to another on a single drive system.
PATCH	Inserts program update and modification information.
SOSXFER	Transfers SOS data files to CP/M diskettes.
TIME	Sets or reads the Apple III internal clock.
TURNKEY	Allows execution of a program or command when the Apple III is booted with a cold start.

### **CP/M Program Compatibility**

The Apple SoftCard III runs most CP/M application programs (subject to memory limitations) that are supplied or converted to the CP/M format.

### **Microsoft BASIC Interpreter Specifications**

Version:	Release 5.2
ANSI Standard:	Meets the requirements set forth in the document BSRX3.60-1978 which defines the minimum requirements for the BASIC language.
Memory Requirements:	Occupies 24K of memory.

## **Index**

### **A**

Apple III  
 CP/M I/O configuration 19  
 I/O bus 21  
 I/O communication 19-21  
 internal clock 78-79  
*Owner's Manual* 22, 56  
 peripheral connector slots 11, 13  
 ProFile I/O configuration 22  
 SOS device drivers 19-22  
 SOS operating system 19  
*Standard Device Drivers Manual* 22, 27  
 System Configuration Program 21-22, 82  
 System Utilities diskette 22  
 Volume Configuration Utility Program 22  
 ASM transient program 39-40  
 Assembly language programming 39-40

### **B**

Backspace key 25  
 Backup procedures 16-18  
 Binary code 40  
 Block devices (SOS) 19, 52-54  
 Boot procedure (CP/M) 15  
 BOOT utility program 48-50  
 Built-in commands 24  
 Built-in commands (CP/M) 33

### **C**

CAT utility program 48-49, 51, 80  
 Character buffering 55  
 Character devices (SOS) 19, 52-53  
 Character output (CP/M) 25-27  
 Circuit board 2  
 Clock rate 92  
 Cold start 28-29, 50, 52, 79, 89  
 Command level invocation 49-50  
 Command prompt (CP/M) 15  
 CONFIG display 53  
 CONFIG utility program 21-22, 48-49, 52-60, 84-88  
 Control characters (CP/M) 25-27  
 CONTROL-C 28-29, 48  
 CONTROL-E 26  
 CONTROL-H 26  
 CONTROL-J 26  
 CONTROL-M 26  
 CONTROL-P 27  
 CONTROL-R 26  
 CONTROL-RESET 25, 28  
 CONTROL-S 27  
 CONTROL-U 25-26  
 CONTROL-X 27  
 COPY  
 copying diskettes 48, 60-63  
 CP/M boot diskettes 66-70  
 CP/M system diskettes 63-70

*COPY (continued)*

- creating system diskettes 63-70
- error messages 63
- utility program 48-49, 60-70

*COPY* utility program 48-49, 60-70

*CP/M*

- <d:> command 39
- ASM transient program 39-40
- boot procedure 15
- built-in commands 24, 33
- changing diskettes 29
- changing I/O configuration 21-22
- character buffering 55
- cold start 28-29, 50, 52, 79, 89
- command level 30, 49-50, 61, 64, 73-74
- command prompt 15
- CONFIG utility program 21-22, 48-49, 52-60
- control characters 25-27
- CP/M to SOS device assignments 53-56
- currently logged drive 30, 39
- data diskettes 28-29, 63-65
- DDT transient program 39, 41
- DIR command 15, 25, 33-35
- disk drive assignments 56-59
- disk drive identifier 30
- DRIVER.SOS file 21-22, 29, 52, 56, 58-59, 67-70, 72, 74-78, 82, 89
- DUMP transient program 40-41
- ED transient program 40-41
- ERA command 35
- error messages 44-45
- extensibility of commands 25
- file naming conventions 30-33
- filename extension 30-31
- filenames 30-33
- filespecs 30-33
- general description 3

*CP/M (continued)*

- I/O communication 19-21
- I/O configuration 19, 21-22, 52
- keyboard differences 25
- line editing commands 25-27
- LOAD transient program 40, 42
- logical devices 20-21, 52-58
- microprocessors 3
- operating system description 24-25
- output control 27
- physical device assignments 52-58
- physical devices 20-21, 52-58
- PIP restrictions 42
- PIP transient program 40, 42 65, 69, 90
- printer echo 27
- ProFile configuration procedure 84-88
- ProFile disk space expansion 89-90
- ProFile loading procedure 88-89
- ProFile space allocation 82-84
- ProFile usage 82
- REN command 36
- SAVE command 36-37
- SOSXFER utility program 21-22
- specifications 93
- STAT transient program 21, 40, 42-43, 55
- SUBMIT transient program 40, 43
- system boot diskettes 28-29, 66-70
- system diskettes 28-29, 60-70
- text editing 41
- transient commands 24-25, 39-43
- transient programs 24-25, 39-43

*CP/M (continued)*

- TYPE command 37
- types of diskettes 28-29
- USER command 38
- verification 15
- warm start 28-29, 89
- wild card character (\*) 32-33
- wild card filename specifications 32-33
- XSUB transient program 40, 43

Currently logged drive (CP/M) 30, 39

Cursor movement keys 25-26

**D**

- Data diskette copy switches 63-65
- Data diskettes (CP/M) 28-29
- DDT transient program 39, 41
- Debugging tool 39, 41
- Device drivers (SOS) 19-22, 52-60
- Digital Research, Inc. x
- Digital Research license x-xii
- DIR command 15, 25, 33-35
- Disk drive assignments 56-59
- Disk drive identifier (CP/M) 30
- Disk drive labels 14
- Diskette format switch 63-65
- Documentation vii-ix
- DRIVER.SOS file 19, 21-22, 29, 52, 56, 58-59, 67-70, 72, 74-78 82, 89
- DUMP transient program 40-41

**E**

- ED transient program 40-41
- ERA command 35
- Error messages 44-45
- Extensibility of CP/M commands 25

**F**

- File directories 51
- File naming conventions (CP/M) 30-33
- File size display 51
- File transfer programs 71-72, 74-78
- Filename extension (CP/M) 30, 31
- Filenames 30-33
- Filespecs 30-33
- File specification 30-33

**H**

- Handling precautions 10

**I**

- I/O communication (Apple) 19-21
- Installation procedure 10-14

**K**

- Keyboard differences (CP/M) 25

**L**

- Line editing
  - Apple III standard console control keys 27
  - command line corrections 16
  - CP/M commands 25-26
  - Microsoft BASIC Interpreter 3-4
- LOAD transient program 40, 42
- Logical devices 20-21, 52-58

**M**

- Mass-storage medium (SOS) 83
- Master diskette 6, 15, 16, 28-29, 48, 84-90
- MFT utility program 48-50, 65, 67, 71-72
- Microprocessors 2-3



Microsoft BASIC Interpreter  
3-4, 94  
Multiple drive copy procedure  
17-18  
Multiple drive systems 17-18,  
39, 68-70, 77, 86-89

**N**

NULL character device 53

**O**

Operating system description  
24-25  
Operating systems description  
2-3  
Output control (CP/M) 27

**P**

Package contents 5-6  
PATCH utility program 49,  
73-74  
Peripheral connector slots  
10-14  
Physical device assignments  
52-58  
Physical devices 20-21, 52-58  
PIP transient program 40, 42,  
65, 69, 90  
Power consumption 93  
Printer output (CP/M) 27  
ProFile  
CAT command 51  
cold start 28-29  
CP/M configuration 84-88  
CP/M operating system 82-89  
CP/M space allocation 82-84  
CP/M space expansion 89-90  
CP/M usage 88-90  
disk capacity 83-84  
formatting notes 64-65  
I/O configuration 22  
loading CP/M 88-89  
*Owner's Manual* 82  
space allocation 82-84

*ProFile (continued)*

STAT transient program 42-43  
user areas 38  
volume 83  
Volume Configuration Program  
22, 83-84  
Program development commands  
39-43  
Program level invocation 49-50

**R**

REN command 25, 36  
RESET key 25  
RUBOUT 27

**S**

SAVE command 36-37  
Single drive copy procedure  
16-17  
Single drive systems 16-17,  
28-29, 66-68, 71-72, 75-77  
Single file transfer program (MFT)  
71-72  
SoftCard III  
backup procedures 16-18  
BOOT utility program 48-50  
CAT utility program 48-49, 51  
circuit board 2  
circuit board installation 10-14  
circuit board size 93  
circuit board specifications  
92-93  
clock rate 92  
concept 2  
CONFIG error messages  
59-60  
CONFIG utility program  
21-22, 48-49, 52-60, 84-88  
COPY error messages 63  
copying diskettes 48, 60-63  
creating system diskettes  
63-70  
design credits x

*SoftCard III (continued)*

documentation vii-ix, 6  
general specifications 92-93  
handling precautions 10  
master diskette 15-16, 28-29,  
48, 84-90  
master diskette files 6  
MFT utility program 48-50,  
65, 67, 71-72  
microprocessor 2-3  
multiple drive copy procedure  
17-18  
operation modes 93  
package contents 5-6  
PATCH error messages 74  
PATCH utility program 49,  
73-74  
power consumption 93  
ProFile usage 82, 88-90  
program level invocation  
49-50  
single drive copy procedure  
16-17  
SOSXFER error messages 78  
SOSXFER utility program 49,  
52, 56, 60, 74-78, 85-87  
syntax notation ix  
system requirements 7  
TIME utility program 49,  
78-79  
TURNKEY utility program 49,  
78-79  
utility program features 5,  
48-80  
utility programs 48-82  
SOS  
block devices 19, 52-54  
character devices 19, 52-53  
device drivers 19-22, 52-60  
mass-storage medium 83  
NULL character device 53  
SOS-CP/M Utilities diskette 5,  
22, 84-88  
SOS.DRIVER file 19, 21-22,  
52, 82

*SOS (continued)*

System Configuration Program  
19, 21-22  
Volume Configuration Program  
22, 83-84  
SOS-CP/M Utilities diskette 6,  
22, 84-88  
SOSXFER error messages 78  
SOSXFER utility program  
21-22, 49, 56, 60, 74-78, 85-87  
Space allocation procedure  
82-84  
Specifications 92-94  
*Standard Device Drivers  
Manual* 22, 27  
STAT transient command  
51, 55, 57-58  
STAT transient program 21, 40,  
42-43  
SUBMIT transient program 40,  
43  
Syntax notation ix  
System boot diskettes (CP/M)  
28-29  
System Configuration Program  
(SCP) 19, 21-22, 82  
System diskette switch 63-64  
System diskettes (CP/M) 28-29  
System requirements 7  
System Utilities diskette 22

**T**

Text editor 41  
TIME utility program 49, 78-79  
Transient commands (CP/M)  
39-43  
Transient programs 24-25, 90  
Transient programs (CP/M)  
24-25, 39-43  
Turnkey programs 43, 79  
TURNKEY utility program 49,  
79-80  
TYPE command 37  
Types of diskettes (CP/M) 28-29

**U**

USER command 38

**V**

Volume (SOS) 82

Volume Configuration Program  
22, 83-84

**W**

Warm start 28-29, 52, 89

Wild card character (\*) 32-33

Wild card file specifications 51

Wild card filename specifications  
(CP/M) 32-33

Word processor 41

**X**

XSUB transient program 40, 43

**Z**

Z80A microprocessor 92-93